



MOTOROLA

GM300

Mobile Radios

146 - 174 MHz

449 - 470 MHz

Service Manual

radius™
DIVISION OF MOTOROLA INC.

GM300
VHF & UHF
Mobile Radios

CONTENTS

Model Charts.....	2
Accessories.....	4
Radio Specifications.....	6
Radio Disassembly & Re-assembly.....	7
Theory of Operation.....	11

Circuit Board Diagrams & Schematics

VHF RF Board.....	23
UHF RF Board.....	25
2-Layer Logic Board.....	27
4-Layer Logic Board.....	30
VHF Power Amplifier.....	33
UHF Power Amplifier.....	34
Front Panel Filter Board.....	35
Display Board.....	36
Volume / Microphone Board.....	37
Microphone.....	38
Radio Exploded View and Mechanical Parts List.....	39
Parts Lists for all boards.....	41

GM300

VHF Mobile Radio

146 - 174 MHz

X = Indicates one of each required

* = Part of HCN3503A

Model	Freq	Version					Item	Description
M33GMC20D2A_	8	Scan					HLD8029A	RF BOARD, 12.5kHz
M33GMC20C2A_	16	Scan & Signalling					HLD8031A	RF BOARD, 20/25kHz
M33GMC00C2A_	16	Scan & Signalling					HLD3502A	PA KIT, 10-25 WATT
M33GMC00D2A_	8	Scan					HLN8074A	LOGIC BOARD, (MASKED) <i>8</i>
			X	X			HLN8070A	LOGIC BOARD, (EXPANDED) <i>16</i>
						X	HLN8122A	FRONT PANEL LENS, 8 FREQ.
			X	X			HLN8123A	FRONT PANEL LENS, 16 FREQ.
			X	X	X	X	HHN8073A	HOUSING
			X	X	X	X	HCN3503A	CONTROL HEAD
			*	*	*	*	HLN8071A	VOL/MIC.BOARD
			*	*	*	*	HLN8072A	FRONT PANEL HDWR KIT
			*	*	*	*	HLN8075A	DISPLAY BOARD
			X	X	X	X	HKN4137AR	POWER CABLE KIT
			X	X	X	X	HMN3413A	MICROPHONE W/HANG UP
			X	X	X	X	HLN8076A	CHASSIS HDWR KIT
			X	X	X	X	HLN5189AR	INSTALLATION KIT
			X	X	X	X	HLN8121A	GM300 NAMEPLATE KIT
				X	X		HLN8120A	ROM KIT <i>16</i>
			X	X	X	X	6880902Z09	OWNERS MANUAL
			X			X	6880902Z26	OPERATORS CARD (8 FREQ.)
				X	X		6880902Z41	OPERATORS CARD (16 FREQ.)

GM300

UHF Mobile Radio

449 - 470 MHz

X = Indicates one of each required

* = Part of HCN3503A

Model				Freq	Version
M34GMC20D2A_				8	Scan
M34GMC20C2A_				16	Scan & Signalling
M34GMC00C2A_				16	Scan & Signalling
M34GMC00D2A_				8	Scan

				Item	Description
		X	X	HLE8030A	RF BOARD, 12.5kHz
X	X			HLE8032A	RF BOARD, 20/25kHz
X	X	X	X	HLE3501A	PA KIT, 10-25 WATT
X			X	HLN8074A	LOGIC BOARD, (MASKED)
	X	X		HLN8070A	LOGIC BOARD, (EXPANDED)
X			X	HLN8122A	FRONT PANEL LENS, 8 FREQ.
	X	X		HLN8123A	FRONT PANEL LENS, 16 FREQ.
X	X	X	X	HHN8073A	HOUSING
X	X	X	X	HCN3503A	CONTROL HEAD
*	*	*	*	HLN8071A	VOL/MIC.BOARD
*	*	*	*	HLN8072A	FRONT PANEL HDWR KIT
*	*	*	*	HLN8075A	DISPLAY BOARD
X	X	X	X	HKN4137AR	POWER CABLE KIT
X	X	X	X	HMN3413A	MICROPHONE W/HANG UP
X	X	X	X	HLN8076A	CHASSIS HDWR KIT
X	X	X	X	HLN5189AR	INSTALLATION KIT
X	X	X	X	HLN8121A	GM300 NAMEPLATE KIT
	X	X		HLN8120A	ROM KIT
X	X	X	X	6880902Z09	OWNERS MANUAL
X			X	6880902Z26	OPERATORS CARD (8 FREQ.)
	X	X		6880902Z41	OPERATORS CARD (16 FREQ.)

ACCESSORIES

Radius offers several accessories to increase communications efficiency. Many of the accessories available are listed below, but for a complete list, consult your Radius dealer.

Antennas:

HAD4007_R	VHF 146-150.8 MHz, 1/4 wave roof mount
HAD4008_R	VHF 150.8-162 MHz, 1/4 wave roof mount
HAD4009_R	VHF 162-174 MHz, 1/4 wave roof mount
HAD4014_R	VHF 146-172 MHz, 3db gain roof mount
HAE4003_R	UHF 450-470 MHz, 1/4 wave roof mount
HAE4011_R	UHF 450-470 MHz, 3.5 db gain roof mount
HAE4019_R	UHF 450-470 MHz, 5 db gain roof mount

Microphones:

HMN3596_R	Compact Microphone with 7 foot cord
HMN1035_R	Heavy Duty Palm Microphone with 10.5 ft. cord
HMN1037_R	Touch-code Microphone with hang-up clip
TDN8305_R	Touch-code Mic. with backlit keypad & hang-up clip
TMN6169_R	Touch-code Mic. with memory dial, backlit keypad & hang-up clip
HMN3141_R	Handset with hang-up cup
HLN9559_R	7 foot coil cord Heavy Duty Microphones
HLN9560_R	10.5 foot extended coil cord for Heavy Duty Microphones
HLN9073_R	Microphone hang-up clip (all microphones)

Installation Accessories:

HLN9284_R	Key lock mount
HLN5189_R	Non-locking bracket
HLN5226_R	Extra stability mount (use with HLN5189)
HLN9450_R	45 - 60 degree floor mount wedge (requires HLN9404)
HLN9404_R	Sleeve mounting bracket
HKN4137_R	VHF/UHF/800 MHz low power cable
HLN5282_R	Mini-U connector (all bands)
HKN9557_R	PL259/Mini-U antenna adapter - 8 inch cable
HLN8027_R	Mini - UHF to BNC antenna adapter
HLN8097_R	Removable slide mount tray package
HLN8098_R	Radio slide mount tray
HLN8099_R	Vehicle slide mount tray
HLN8143_R	Remote mount kit (17 FT. length)
HLN8144_R	Remote mount kit (8 FT. length)

ACCESSORIES (cont'd)

Control Station Accessories:

HMN1038_R	Desk Microphone
HPN1007_R	Power supply (10 and 25 watt models)
HKN4139_R	Low power control station power cable (VHF/UHF/800 MHz)
HLN5292_R	Base tray for control station

Accessories / Kits Interfacing with the 16 Pin Connector:

HKN9327_R	Ignition switch cable
HSN8145_R	7.5 Watt external speaker - for receiver audio
HLN9457_R	Hardware kit-includes 16 conn. pins, (9) 8" wires with pins & extra housing

Manuals:

6880902Z26	Operator's card - 8 channel radios
6880902Z41	Operator's card - 16 channel radios
6880902Z09	Owner's manual
6880902Z32	Service manual

Performance Specifications for the GM300 Mobile Radio

GENERAL

VHF		UHF	
Model Series:	M43LRC	M44LRC	
Frequency:	146 - 174 MHz	449 - 470 MHz	
Channel Capacity:	8 or 16 channels		
Dimensions:	2" x 7" x 7.75" (50.8 x 178 x 198 mm)		
Weight:	61 oz. (1.7 kg)		
Typical Currents			
Rated Audio (7.5 W):	1.5 A	1.5 A	
Transmit:	7.0 A	7.5 A	
Standby:	400 mA	400 mA	
Squelch Capability:	Tone Coded, Digital Coded and/or Carrier Squelch		

TRANSMITTER

	VHF	UHF
RF Output:	10-25W (Variable)	10-25W (Variable)
Freq. Separation:	28 MHz	21 MHz
Freq. Stability: (-30 C to +60 C)	± .00025%	± .00025%
Spurs/Harmonics:	.25 uW	.25uW
Audio Response: (from a 6 db/oct. Pre-Emphasis: 300 to 3000 Hz. 2550 @ 12.5 kHz)	+1, -3 db	+1, -3 db
Audio Distortion: (@ 1000 Hz. 60% Rated Max. Dev.)	< 3% EIA	< 3% EIA
FCC Designation:	ABZ99FT3030	ABZ99FT4030
FCC Modulation:	16KOF1D, 15KOF2D, 16KOF3E	
Output Impedance:	50 ohms	50 ohms
Mod. Sensitivity:	80mV for 60% Max. Deviation at 1000 Hz	
FM Noise		
EIA: 45db (40db @ 12.5 kHz)	40db (35db @ 12.5 kHz)	40db (35db @ 12.5 kHz)
CEPT 84: 55db (50db @ 12.5 kHz)	50db (45db @ 12.5 kHz)	50db (45db @ 12.5 kHz)

RECEIVER

		VHF		UHF	
Channel Spacing:		12.5 kHz	20/25/30 kHz	12.5 kHz	20/25 kHz
Freq. Separation:		28 MHz		21 MHz	
Sensitivity					
EIA: 12 db SINAD:		.35uV	.30uV	.35uV	.30uV
CEPT 84: 20db SINAD:		.45uV	.40uV	.45uV	.40uV
Squelch:		10 db SINAD		10 db SINAD	
Selectivity					
EIA:		-70db	-80db	-65db	-75db
CEPT 84:		-70db	-80db	-65db	-75db
Intermodulation					
EIA:		-70db	-78db	-65db	-75db
CEPT 84:		-73db	-73db	-70db	-70db
(local Mode)					
EIA:		-70db	-78db	-65db	-75db
CEPT 84:		-78db	-78db	-75db	-75db
Frequency Stability: (-30 C to +60 C)		± .00025%		± .00025%	
Spur Rejection					
EIA:		-80db		-75db	
CEPT 84:		-75db		-70db	
Image Rejection					
EIA:		-80db		-75db	
CEPT 84:		-80db		-75db	
Audio Output: 8 ohm Ext.					
EIA (@ < 5% Dist.):		7.5W		7.5W	
CEPT 84 (@ < 10% Dist.):		5.0W		5.0W	
EIA Usable Bandwidth:		1.2kHz	2.0kHz	1.2kHz	2.0kHz
Input Impedance:		50 ohms		50 ohms	

Optional Signalling Features with RapidCall Package

Available in 16-Channel Models Only

Signalling Format:	Call Alert	Voice SelCall	Emergency	Radio Check	PTT ID
MDC-1200:	x	x	x	x	x
Quik-Call II:	x	x			
DTMF:	x	x			x
Star (encode only):			x		x

Radio Disassembly / Re-assembly

1. Radio Disassembly and Assembly

1.1 TO REMOVE CONTROL HEAD & CHASSIS COVERS

- (1) Remove control head mounting screws (figure 1). Pull control head off and away from the radio. Carefully remove control head connectors from chassis.
- (2) Remove the two chassis cover screws from each side (figure 1). Remove top and bottom covers from chassis.

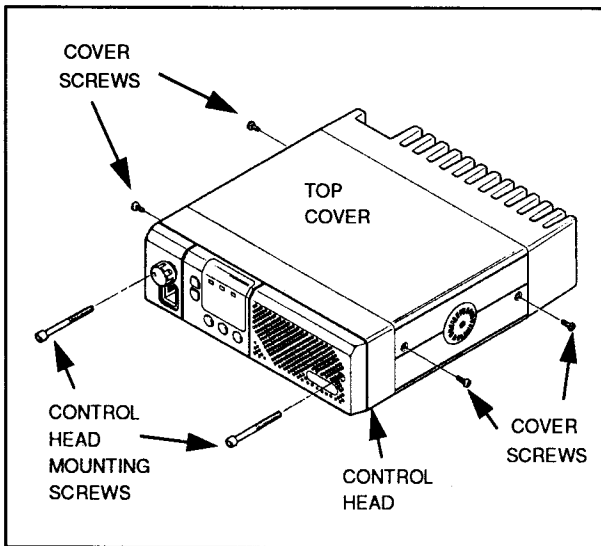

Figure 1.

1.2 TO REMOVE RF CHASSIS SHIELD

Remove RF chassis shield by prying each of the four corners at the indentations provided (figure 2). Be careful not to over bend any one corner.

1.3 TO REMOVE THE P.A. HEATSINK

- (1) Disconnect the transmit and receive coaxial cables from the RF board (figure 3).
- (2) Disconnect the 6-pin connector from the logic board (figure 4).

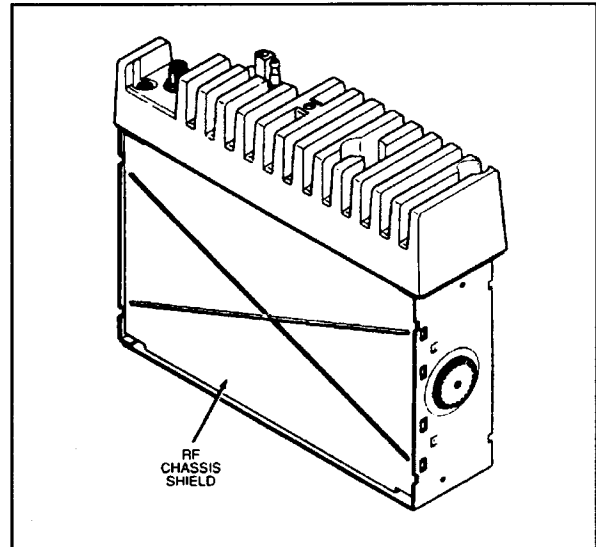

Figure 2.

- (3) Remove the heatsink mounting screws (figure 4). Pull heatsink off of chassis while carefully feeding the transmit and receive coax cables through their respective holes in the chassis.

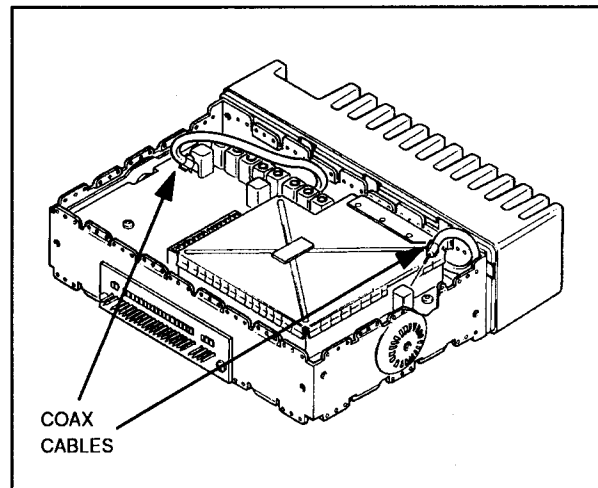

Figure 3.

1.4 TO REMOVE THE RF CIRCUIT BOARDS

- (1) After the P.A. heatsink has been removed, pry off the RF shield (figure 5). Be careful not to over bend any one corner or side.
- (2) After removing the RF shield then remove all the

RF board mounting screws and take out the RF board (figure 5).

1.5 TO REMOVE THE LOGIC CIRCUIT BOARD

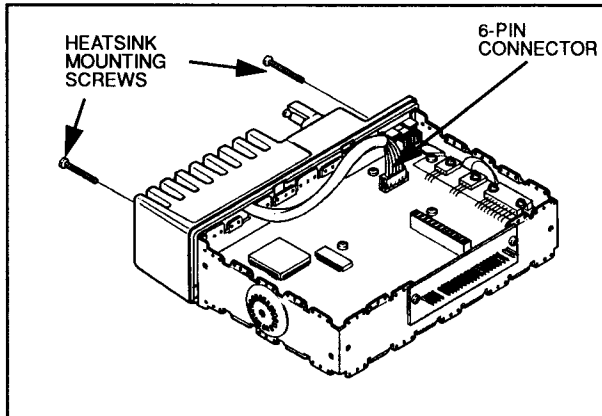

Figure 4.

(1) After the RF board has been removed, turn the radio over and pry off the logic shield, again being careful not to bend any one corner or side.

(2) Remove all logic board mounting screws (figure 6).

(3) Now remove the two filter board screws from the front of the chassis (figure 6). The logic and filter boards can now be lifted out of the chassis.

(2) Unsolder the A+ power connector feed-thru leads and the antenna connector lead (figure 8).

(3) UHF ONLY - Remove the stud mount transistor mounting nut from the back of the heatsink (figure 9).

(4) Remove two power device mounting screws and all P.A. board mounting screws (figure 8), and then take out the P.A. board.

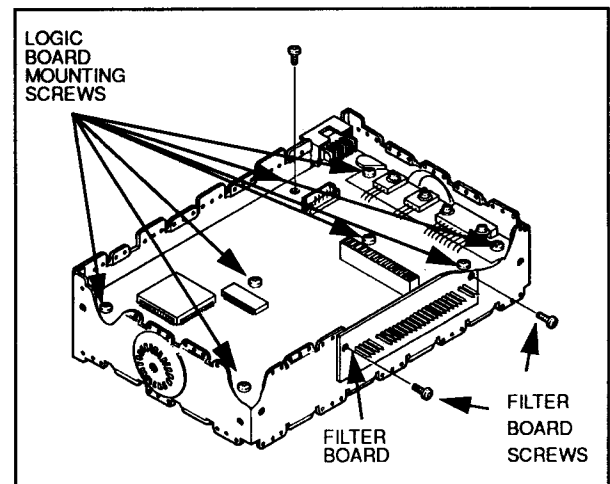

Figure 6.

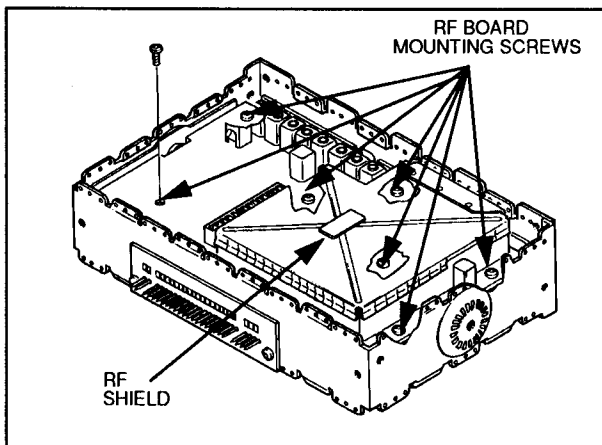

Figure 5.

1.7 TO RE-ASSEMBLE THE RADIO

Reverse the disassembly procedure and tighten all screws to the torques specified in Table 1.

1.6 TO REMOVE THE P.A. CIRCUIT BOARD

(1) Remove the power amplifier shield by carefully prying each corner and side until you can slide the shield off easily (figure 7). Remove the shield completely by guiding the coaxial cables out.

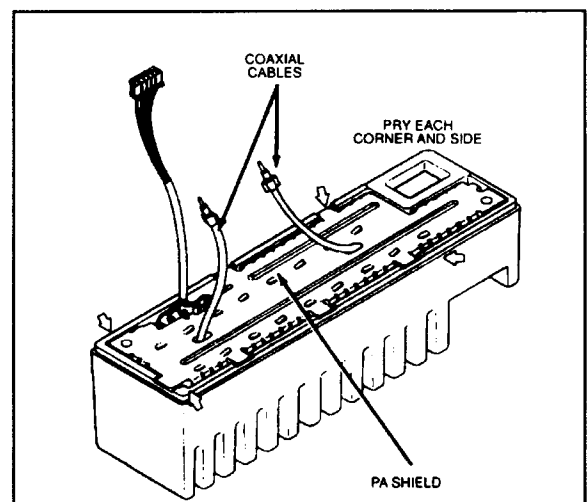

Figure 7.

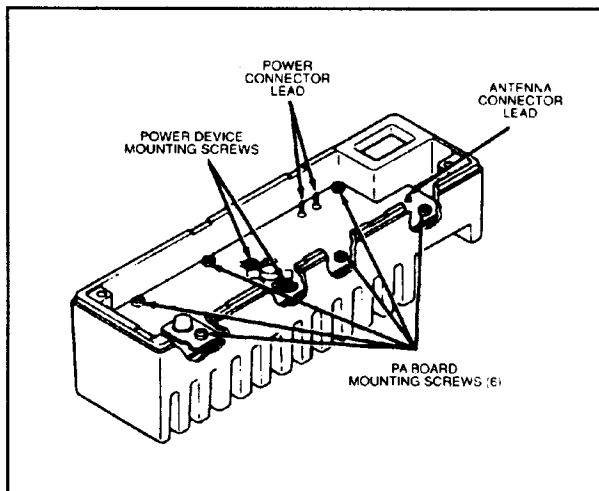

Figure 8.

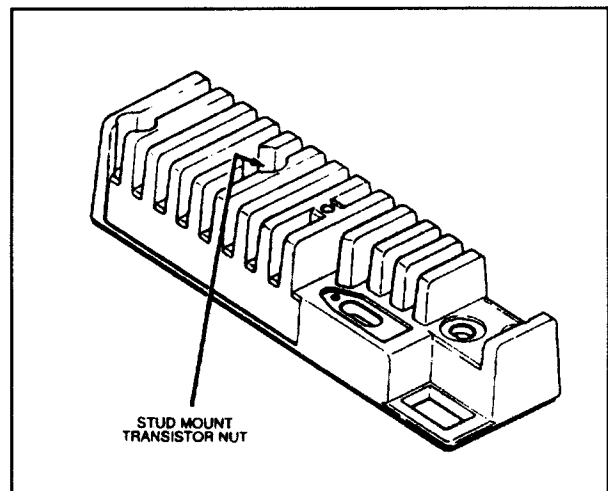

Figure 9.

Table 1. Fasteners, Tools and Torques

Part Number	Description	Location	Qty	Drv	Input Torq.	Repair Torq.
03-10945A11	M3 x 8 Plastite Slit Torx Pan Hd.	Control Head Bd. and Internal speaker	9	T10	8 in.-Lbs	7 in.-Lbs.
03-80270L01	M4 x .7 x 38 Mach. Torx Cap Scr Blk	Control Head Mtg.	2	T15	8 in.-Lbs.	8 in.-Lbs.
03-80271L01	M4 x .7 x 27 Mach. Slit Torx Pn Hd Blk	Heat Sink Mtg.	2	T15	12-14 in.-Lbs.	12-14 in.-Lbs.
03-10943M04	M2.5 x 8 Taptite Slit Torx Pan Hd	Logic Heatsink Device Mtg.	2	T8	6-8 in.-Lbs.	4-6 in.-Lbs.
03-10943M09	M3 x 6 Taptite Slit Torx Pan Hd	RF Board Mtg. Logic Board Mtg. Chassis Feedthru Plt Front Panel Filter Bd	7 6 2 2	T10	8-10 in.-Lbs.	6-8 in.-Lbs.
03-10943M10	M3 x 8 Taptite Slit Torx Pan Hd	PA Device/Bd Mtg. Logic Htsink to Chassis	8 2	T10	11-13 in.-Lbs.	8-10 in.-Lbs.
03-10943M11	M3 x 10 Taptite Slit Torx Pan Hd	Power connector Device to Logic Htsink	2 2	T10	9-11 in.-Lbs	7-9 in.-Lbs.
03-10943R55	M3 x 8 Taptite Torx Flt Hd Blk	Chassis covers	4	T10	8-10 in.-Lbs.	6-8 in.-Lbs.
02-00007003	Hex Nut 8-32	PA -Stud Device Mtg.	1	5/16" Hex	5 in.-Lbs.	5 in.-Lbs.
04-00136334	Flat Washer	Device to Logic Htsink Power connector	2 2	--	---	---
04-80943V01	Washer-Lock 3/8 Ext, Stl. Zinc	Antenna connector	1	--	---	---
09-80131M01	3/8 Nut	Antenna connector	1	3/8" Hex	18-20 in.-Lbs.	18-20 in.-Lbs.
38-80041M01	Plug, button	Heat sink plug	1	--	---	---
03-11994A23	5-20 x 7/8" Plastite Phl Pan Hd.	Mic. Rear Housing to Front Housing	3	1	9-11 in.-Lbs.	9-11 in.-Lbs.

2. Alignment

The advanced design and manufacturing procedures eliminate the need for traditional tuning tasks.

All the circuits in the GM300 radio have been aligned at the factory with specialized equipment.

Alignment in the field should not be attempted or necessary.

3. Programming

The GM300 radios can be programmed in the field to these parameters:

- * Receive and transmit frequencies
- * Transmit Frequency Adjustment (warp)
- * PL or DPL encode and decode Codes
- * Transmit Power Output
- * Transmit Deviation
- * Time Out Timer

Configuration information for programming these parameters is contained in the GM300 RADIO SERVICE SOFTWARE package HVN8177A for 5.25 inch drives and 3.5 inch drive diskettes.

A personal computer (P.C.) and the appropriate software diskette will be required in addition to the items listed in Recommended Test Equipment.

We strongly suggest the servicer become familiar with the programming techniques applicable to the GM300 radios.

5. Recommended Test Equipment

R2001D: Communication Systems Analyzer

or

R2200B: Service Monitor

R1011B: Power Supply

R1037A: Digital Multimeter

or

R1024B: Digital Multimeter

6. Board Replacement and Calibration

Replacement of the Logic board, RF board, or Power Amplifier requires that recalibration must be performed with the Motorola Radio Service Software.

The procedures for calibration are covered in the GM300 Radio Service Software Manual.

Failure to perform the required calibration procedure will affect the performance of the Reference Oscillator, RF Power Leveling and Protection, and Transmitter Modulation over frequency and temperature. An uncalibrated radio may not comply with your Local Communications Agency rules and may be unreliable at temperature extremes.

The GM300 radio was designed to be serviced at the board level only. There are a number of non-field serviceable parts in the radio. Field replacement of these parts will affect the factory calibrated numbers on the tuning label. If any of these parts fail, board replacement is the only way to service the radio.

ERROR TONES

TONE

- (1) High pitch Beep (900Hz 119ms) on initial turn on or when key is pressed.
- (2) Low pitched tone (163Hz) for 5 seconds following turn on.
- (3) Low frequency (163Hz) continuous tone present whenever radio is on.
- (4) Low pitch beep (300Hz 200 MS) when a button is pressed.
- (5) Low frequency (150Hz or 112.5Hz) continuous tone while PTT is held.

PROBLEM

- (1) Normal operation - no error.
- (2) Code plug error.
For all code plug errors try to re-program radio. If this does not clear the fault or if problem recurs, replace the logic board.
- (3) Logic board failure. Replace logic board.
- (4) Button is not allowed in the current operating condition. Change operating condition (select another mode, etc.)
- (5) Transmit is not allowed. If it was time-out-timer, you may release PTT then continue your call.

1. RF Board

1.1 VHF RECEIVER FRONT END, 146-174 MHz

The received signal applied to the radio's antenna input connector is first routed through the harmonic filter/antenna switch on the RF Power Amplifier Board, and then applied via coax to J4 on the RF Board. The insertion loss of the harmonic filter/antenna switch is less than 1 dB.

The signal applied to J4 is routed to a fixed-tuned 4 pole filter having a 3 dB bandwidth of 57 MHz and a 1 dB bandwidth of 37 MHz centered at 160 MHz. Insertion loss is 1.5 dB typically, and 2 dB at 146 MHz. Attenuation for image protection is 32 dB at 236 MHz, with increasing attenuation at higher frequencies.

The output of the filter is matched to the base of RF amplifier Q1, which provides 12 dB of gain and has a noise figure of 3.6 dB. Current source Q2 is used to maintain the collector current of Q1 constant at 26 mA. Diode CR2 clamps excessive input signals, protecting Q1.

The output of Q1 is applied to a 3 pole fixed-tuned filter having a 3 dB bandwidth of 59 MHz and a 1 dB bandwidth of 48 MHz centered at 160 MHz. Insertion loss is 1.3 dB. Attenuation for image protection is 35 dB at 236 MHz, with increasing attenuation at higher frequencies. Additional image protection is provided by the transmitter harmonic filter, which provides at least 20 dB of attenuation at 236 MHz and above.

A pin diode attenuator is located between the 3 pole filter and the first mixer. In the Distance mode, Q5 and Q6 are turned on, CR5 is forward-biased which bypasses R12, and no loss is introduced. In the Local mode, Q5, Q6 and CR5 are off, inserting 10 dB of attenuation due to R12. Because the attenuator is located after the RF amplifier, receiver sensitivity is reduced only by 5 dB, while the overall third order input intercept is raised by 15 dB. Thus, the Local mode significantly reduces the susceptibility to IM-related interference.

The first mixer is a passive, double-balanced type consisting of T1, T2 and U1. This mixer provides all of the necessary rejection of the half-IF spurious response, since the improvement due to filter selectivity is negligible for much of the band. High-side injection at +13 dBm is delivered to the first mixer from the second RX buffer in the synthesizer circuit.

The mixer output is connected to a diplexer network which matches its output to the first IF amplifier Q51 at the IF frequency of 45.1 MHz, and terminates it in a 50 ohm resistor, R51, at all other frequencies.

1.2 UHF RECEIVER FRONT END, 449-470 MHz

The received signal applied to the radio's antenna input connector is first routed through the harmonic filter/antenna switch on the RF Power Amplifier Board, and then applied via coax to J4 on the RF Board. The insertion loss of the harmonic filter/antenna switch is less than 1 dB.

The signal applied to J4 is routed to a tunable 3 pole shunt resonator filter having a 3 dB bandwidth of 70 MHz and a 1 dB bandwidth of 50 MHz centered at 460 MHz. Insertion loss is 1.8 dB. Attenuation for image protection is 33 dB at 380 MHz, with increasing attenuation at lower frequencies.

The output of the filter is matched to the base of RF amplifier Q1, which provides 16 dB of gain and has a noise figure of 1.9 dB. Current source Q2 is used to maintain the collector current of Q1 constant at 30 mA. Transistors Q3 and Q4 turn off the dc supply to Q1 and Q2 during transmit, reducing the dissipation in Q1. Diodes CR2 and CR3 clamp excessive input signals, protecting Q1.

The output of Q1 is applied to a tunable 4 pole shunt resonator filter having a 3 dB bandwidth of 45 MHz and a 1 dB bandwidth of 27.5 MHz centered at 460 MHz. Insertion loss is 3.7 dB. Attenuation for image protection is 55 dB at 380 MHz, with increasing attenuation at lower frequencies.

A pin diode attenuator is located between the 4 pole filter and the first mixer. In the Distance mode, Q5 and Q6 are turned on, CR5 is forward-biased which bypasses R12, and no loss is introduced. In the Local mode, Q5, Q6 and CR5 are off, inserting 10 dB of attenuation due to R12. Because the attenuator is located after the RF amplifier, receiver sensitivity is reduced only by 5 dB, while the overall third order input intercept is raised by 15 dB. Thus, the Local mode significantly reduces the susceptibility to IM-related interference.

The first mixer is a passive, double-balanced type consisting of T1, T2 and U1. This mixer provides all of the necessary rejection of the half-IF spurious response, since the improvement due to filter selectivity is negligible at 470 MHz. Low-side injection at +6 dBm is delivered to the first mixer from the second RX buffer in the synthesizer circuit.

The mixer output is connected to a diplexer network which matches its output to the first IF amplifier Q51 at the IF frequency of 45.1 MHz, and terminates it in a 50 ohm resistor, R51, at all other frequencies.

1.3 RECEIVER BACK END

Q51 amplifies the IF signal by approximately 17 dB. The output of Q51 is filtered by a four pole crystal filter (comprised of two matched units Y51A and Y51B). The 3 dB bandwidth of the crystal filter is 14 kHz for 25 kHz channel spacing models, and 8 kHz for 12.5 kHz channel spacing models. The signal is amplified 18 dB by the second IF amplifier Q52, and applied to the input of the receiver system IC U51-19 (see Figure 1).

The 45.1 MHz first IF signal is applied to the second mixer section of U51. A 44.645 MHz crystal oscillator provides the low side injection signal, which is also applied to U51-19. The output of the second mixer is a 455 kHz second IF signal which is filtered by ceramic filter FL51, amplified, filtered by ceramic filter FL52, and applied to the audio detector. As with the crystal filter, the bandwidth of the ceramic filters are narrower for 12.5 kHz channel spacing models than for 25 kHz. The IF test point is located at the output of filter FL52. The level of the 455 kHz signal at this test point is linearly related to the input signal level at the antenna, allowing a convenient metering point for filter tuning and gain measurements.

The audio detector is a peak-differential type, with the necessary phase shift (90° at 455 KHz) provided by L-C network L61. Recovered audio from U51-5 is routed to the receiver audio circuitry on the logic board, and to the squelch circuitry contained in U51. When an on-channel signal is present, the amount of high-frequency audio noise at the detector output is reduced. This change in noise level is sensed to indicate the presence of an on-channel signal. Audio noise at U51-5 is applied to U51-7 via R61 and C82. Extreme high-frequency noise is removed by C81. The noise is amplified and appears at U51-6 where it is coupled via C80 to the SQUELCH adjust pot R60. The output of this control is applied via R59, C79 and C78 to pin 8 which is the input of a limiting amplifier and threshold detector.

Noise levels greater than a preset threshold cause U51-11 to go high. This is buffered by Q53 and routed to the microcomputer circuitry on the logic board. This corresponds to no channel activity. When the noise level decreases below the threshold, due to on-channel quieting, U51-11 goes low, providing a low to the logic circuitry. This implies an on-channel signal is present, causing unmuting of the receive audio path by the microcomputer.

Components R58, C75 and C76 determine squelch time constants as a function of the charging currents supplied by U51. These charging currents vary from weak to strong signal conditions, providing a variable squelch closing time-constant. For weak signals the time constant is long to minimize "chattering" or rapid muting and unmuting of the audio. For strong signals, where the carrier-absent to carrier-present conditions are substantial, the closing time-constant is shortened to minimize the length of the "squelch-tail".

1.4 FREQUENCY SYNTHESIZER

To determine the synthesizer's operating frequency, the microcomputer loads the frequency divider information into the PLL IC U101 (see Figure 2). The PLL IC contains three programmable dividers. The program is serially loaded via the SR DATA line to U101-10. The data is loaded one bit at a time, with each low-to-high transition of the SR CLOCK at U101-11 latching data from shift registers into the reference divider (R), divide-by-N, or divide-by-A latches depending on the control bit. A logic high of the control bit selects the reference counter latch, while a logic low selects the divide-by-N, or divide-by-A counter latch.

After the microcomputer loads data into the PLL IC, the SYNTH LATCH ENABLE line goes low. The synthesizer is then ready to generate a receive first-injection or transmit frequency.

In UHF radios, for example, the latches are loaded with data to give 5 kHz (or 6.25 kHz) at the output of the divide-by-R counter when the reference signal is applied at U101-1, and 5 kHz (or 6.25 kHz) at the output of the divide-by-N counter when the VCO is operating at the desired receive injection or transmit frequency.

During the frequency synthesis, the divide-by-A and divide-by-N counters begin counting down from the programmed values (A and N respectively) at the same time. The modulus control line U101-12 is low so the divide-by-127/128 prescaler divides by 128. Therefore, the effect of the prescaler U102 is to divide the VCO output by 128 and apply it to U102-8. When the divide-by-A counter completes counting down, the control logic sets the modulus control line high, and the divide-by-127/128 prescaler divides by 127 until the divide-by-N counter completes the programmed value on N. After the divide-by-N counter completes counting down, the counters are set back to their programmed values. The effect of the prescaler and divide-by-A, divide-by-N counters is to divide the VCO frequency by a number, N, where:

$$N_T = 128 \times A + 127 \times (N-A) = 127 \times N + A$$

The output of the divide-by-N counter is equal to:

$$f_{VCO} / (127 \times N + A)$$

When the phase-locked loop is locked:

$$f_{VCO} / (127 \times N + A) = 5 \text{ kHz} = f_{VCO} / N^T$$

The reference oscillator frequency is 14.4 MHz and the output of the divide-by-R must be 5 kHz. Therefore:

$$R = 14.4 \text{ MHz} / 5 \text{ kHz}$$

The values of A and N are dependent on the desired VCO frequency which is equal to the transmit frequency, or to the receive frequency minus 45.1 MHz (for UHF radios).

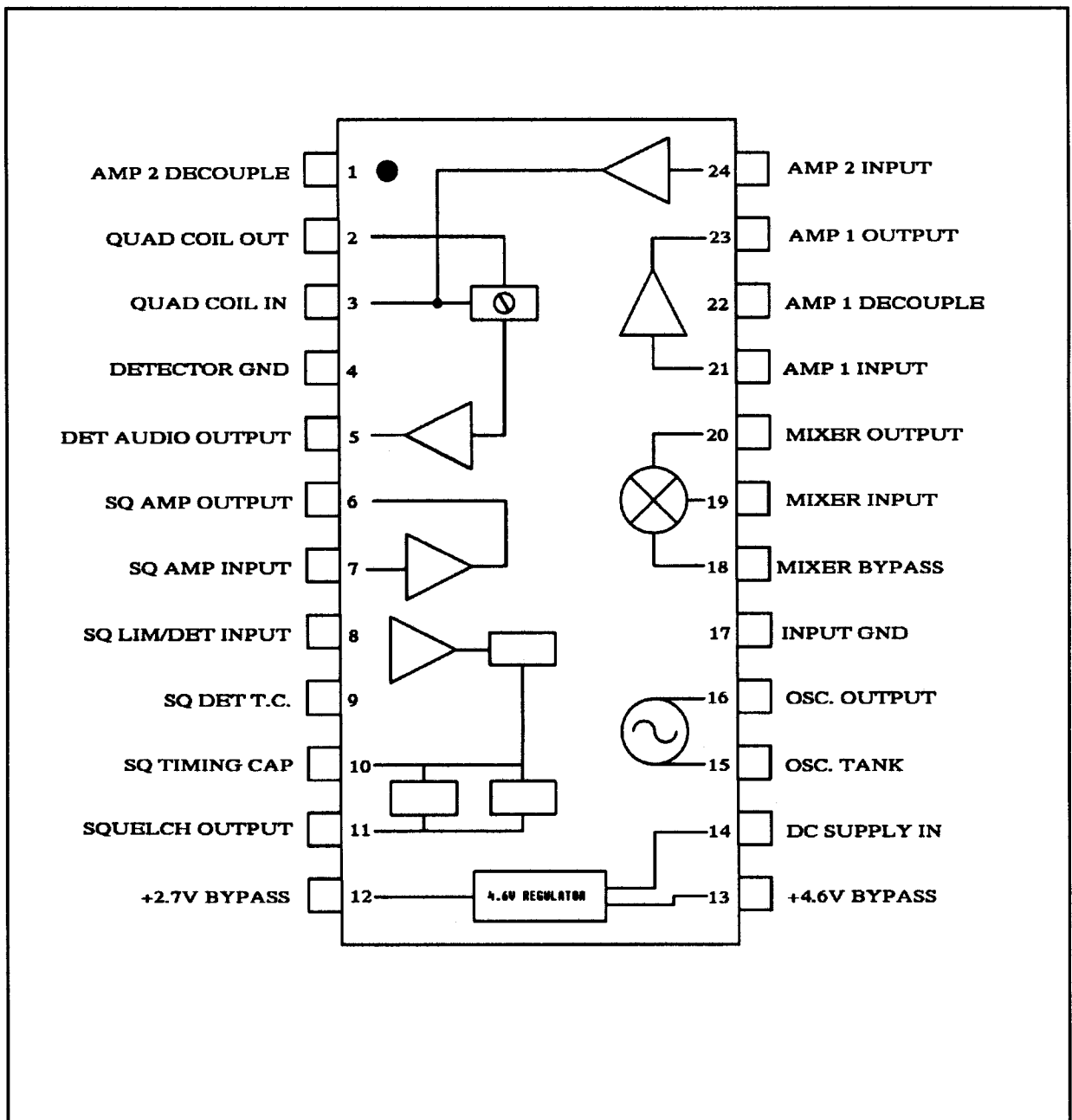

Figure 1. Receiver IC Block Diagram

$N = \text{integer part of } N_T / 127$

$A = \text{remainder of } N_T / 127$

The 5 kHz outputs of the divide-by-A and divide-by-N counters are applied to phase detector A. The output of phase detector A is applied to phase detector B. There are two output signals for phase detector B, phase R (U101-16) and phase V (U101-15), which consist of pulses whose pulse width depends on the phase error between the two signals at phase detector A. If the frequency f_V is greater than f_R , then error information is provided by phase V pulsing low, while phase R remains essentially high. When f_V and f_R are both in phase, both phase V and phase R remain high, except for a small minimum time period, and they both pulse low in phase. These pulses are applied to the charge pump and are used to correct (steer) the VCO frequency.

The above discussion is for a UHF radio with a 5 kHz reference frequency. VHF radios use a divide-by-64/65 prescaler, and the receive VCO frequency is equal to the receive frequency plus 45.1 MHz. Either a 5 or 6.25 kHz reference frequency may be used depending on the desired frequencies and channel spacing.

When the synthesizer is locked, U101-7 applies a high level signal with very narrow negative-going pulses to the out-of-lock detector. The very narrow low pulses have a high average DC level that is not sufficient to turn on transistor Q101. This keeps the voltage across C102 low, which indicates an in-lock condition.

When the synthesizer is out-of-lock, the output of U101-7 becomes a pulsating DC signal with an average DC level that varies between 0.5V and 4.4V. This turns on Q101 and charges C102 to at least 3.0 volts, indicating an out-of-lock condition. Transmitter output and receiver audio are inhibited under these circumstances.

The 5V DC operating voltage for the synthesizer and prescaler is derived from a voltage divider buffered by Q106. Due to the low and relatively constant current drain requirements, a more elaborate regulator is unnecessary.

1.4.1 Charge Pump

The charge pump consists of Q102-Q105. The phase V (U101-15) signal from the PLL IC is applied to Q103 while phase R (U101-16) is applied to Q102. Then the synthesizer is locked, both signals consist of a pulse train with a period of 160 or 200 usec and negative-going pulses. The phase R negative pulse turns off Q102 and brings the emitter of Q104 to 9.6V which turns on Q104. The negative pulse of phase V turns Q103 off which reduces the current flow to R114 and in turn reduces the voltage across R114. This will cause Q105 to turn on and sink current from Q104. When the synthesizer reaches lock, the voltage at the steering line will be between 1.3V and 7.8 V DC. When the synthesizer is reprogrammed to a new frequency, the previous SL voltage would now give a wrong frequency and will cause the phase R and phase V to

have different pulse widths. This will cause Q104 and Q105 to turn on and off at different times, resulting in a series of summed current pulses to the loop filter that charges or discharges C110 to the new SL voltage. If the frequency of the VCO is higher than that of phase R, then C110 discharges; if lower, C110 charges.

1.4.2 Loop Filter

The loop filter consists of R119 through R121 and C109 through C112, as well as C205 and C258 in the VCO compartment. The loop filter is a low pass filter that attenuates noise and rejects the loop reference frequency so that these signals cannot modulate the VCO. The voltage across C110 is the steering line voltage which controls the VCO frequency.

1.4.3 Reference Oscillator

The reference oscillator is a Colpitts design using a 14.4 MHz crystal element. Each crystal has a unique 8-digit temperature coefficient code which must be keyed into the radio during chassis auto tune. The reference oscillator is warped to the desired range by adjusting L151 while supplying $5.2 \pm 0.01V$ DC at J6-9. Further frequency warp adjustment is done electronically by changing the control voltage applied to varactors CR151 and CR152 by the logic board.

Temperature compensation is applied in the same manner, based on the temperature of the crystal as sensed by zener diode VR176, which is physically close to Y151. The forward voltage drop of this diode is proportional to the actual crystal temperature. This forward voltage is amplified by a precision DC amplifier, U176 and associated components, to a DC level sufficient to be read by one of the A/D inputs of the microcomputer on the logic board. The appropriate control voltage is applied, based on the crystal's temperature coefficient code, to maintain ± 2.5 ppm stability over the entire operating temperature range.

For transmissions of PL/DPL or data with low-frequency content, the reference oscillator is modulated to extend the low frequency modulation capability of the synthesizer below the loop filter cutoff frequency. Modulation is applied to the frequency control varactors CR151 and CR152 via J6-13 and REF MOD adjust pot R164.

1.5 VCO's AND BUFFERS

Two VCO's are used, one for transmit and one for receive. These are selected by switching circuitry Q277 through Q279, which applies 8.5V DC supply voltage to the appropriate oscillator and buffers. The incoming 9.6V DC voltage is first filtered by Q276 to remove noise which might be introduced into the VCO's. Q276 acts as a C-multiplier, which effectively multiplies the capacitance of C277 by the gain of transistor Q276. In the receive mode, J6-4 is pulled high by R276, turning off Q277 and Q278, allowing Q279 to conduct and supply RX 8.5V. In the transmit mode, J6-4 is pulled low by the logic board.

Q277 conducts to supply TX 8.5V, and Q278 saturates across the base-emitter of Q279, turning it off.

Each VCO consists of a FET oscillator whose frequency is determined by a parallel L-C network consisting of a tunable coil and a network of varactors. As the steering line varies over the range of 2V to 7.8V DC, the capacitance of the varactors decreases as voltage is raised, causing the oscillator frequency to increase. The transmit VCO has an additional varactor, CR208, which is very lightly coupled to the tank circuit, which provides frequency modulation of the VCO from the audio signal applied at J6-10 and adjusted by VCO MOD adjust pot R302.

Each VCO has an AGC rectifier circuit (CR206 or CR214) which varies the DC gate bias on the VCO FET as a function of the RF output level at the VCO's drain. This helps maintain a more constant VCO output level, and prevents RF voltages from increasing to levels which might cause rectification by the varactors.

Transistors Q204, Q205 are receive buffer amplifiers. These raise the RF output of the VCO to the level required as injection for the first mixer, typically +13 dBm at VHF and +6 dBm at UHF. The RF at Q205's base is sampled and fed back to the synthesizer via buffer Q107, allowing the synthesizer to "know" if the VCO is operating at the correct frequency.

Similarly, transistors Q207, Q208 are transmit buffer amplifiers. These raise the RF output of the VCO to the level required by the RF power amplifier, typically +15 to +17 dBm. The VCO frequency is sampled at Q208's base and fed back to the synthesizer via buffer Q107.

2. Logic Board

There are two versions of logic boards used in GM300 series mobile radios, "masked" and "expanded." The expanded logic board has a shielded compartment which encloses the microcomputer, custom gate array, and external memory IC's, and has a four-layer printed circuit board layout. The masked logic board uses a two-layer circuit board without the shielded compartment, with all software functions contained in a single masked microcomputer IC. In general, the masked logic board is used in 8 channel models with basic signaling capabilities, while the expanded logic board is found in 16 channel models having more elaborate signaling systems or requiring programmable accessory connector I/O's.

The logic board circuitry consists of five major sections:

- DC distribution and regulation
- Microcomputer and logic
- Receiver audio circuitry
- Transmitter audio circuitry
- Transmitter power control circuitry

2.1 DC DISTRIBUTION AND REGULATION

All operating voltage for the radio is supplied from the RF power amplifier's battery input connector J2. This voltage is protected from reverse polarity or excessive positive transients by CR2370 in the VHF PA or CR2670 in the UHF PA, which acts as a power diode for reverse polarity protection, as well as a power transient suppressor due to its reverse avalanche characteristics. The supply voltage is routed to the logic board via J7-5 (UNSW B+).

Whenever UNSW B+ is supplied, a continuous source of 5V DC is applied to pin 2 of the microcomputer from the RAM 5V supply (VR402, CR403, R410 and C408). This maintains the radio's scan list, current operating mode, etc., when the radio is turned off. Due to the storage of C408, this information may be maintained for up to several hours even if the battery supply voltage is interrupted.

When ignition control is not used, UNSW B+ via fuse F801 becomes B+ which is routed through the on-off switch to become SW B+. When ignition control is used, fuse F801 is removed, and the vehicle's ignition-switched voltage is supplied to J3-10 which is the B+ that is routed through the on-off switch to become SW B+. Thus, with ignition control, ignition-controlled voltage must be present at J3-10 for the radio to operate.

When the radio is turned on, SW B+ is routed to the supply pins of opamps U401 and U451 (energizing the 9.6 volt regulator and transmitter power control circuits), to 5 volt regulator U402 (powering the microcomputer and logic circuitry) and to J3-13, the SW A+ sense pin on the accessory connector. The current drawn through the on-off switch is relatively low, less than 400 mA, and the majority is that required by the 5V regulator. All high current stages, such as the RF and audio power amplifiers, operate from UNSW B+ and are controlled by low currents.

The 9.6V regulator uses an opamp as a controlling element. The regulated output voltage is divided by R404 and R405 and compared with an accurate reference voltage (5.03V DC) determined by VR401. The opamp's output voltage (U401A-1) varies the amount of conduction in Q402 and Q401 as necessary to keep these two voltages (U401A-2 and -3) equal. A characteristic of the opamp which allows the regulator to start up is the fact that the output is high when both inputs are low, which occurs momentarily at turn-on. Diode CR401 is used to protect Q401 if the 9.6V line is grounded. When this happens, Q402's base can only be 0.7V DC and Q401 will be turned off. Diode CR402 provides temperature compensation of the regulated output voltage. The 9.6V supply powers the opamps in the receive and transmit audio circuits, the D/A converter, the RF board circuitry, and low level stages of the RF power amplifier.

The 4.8V DC reference is formed by divider R408-R409, filtered by C405, and buffered by unity gain opamp U401B to provide a low-impedance and low noise half-

supply reference voltage for the opamps in the audio circuits.

The 5V regulator uses an IC, U402, to provide operating voltage for the microcomputer and logic circuits and the front panel LED displays. This IC generates a low reset pulse when turned on which is used to initialize the microcomputer at power-up. The timing of this pulse is determined by C409.

2.2 MICROCOMPUTER AND LOGIC

GM300 radios use the Motorola 68HC11E9 microcomputer, U802, which utilizes:

- 7.776 MHz clock rate
- Multiplexed 8 bit address/data lines
- 16 bit addressing
- Internal watchdog circuitry
- Analog to digital conversion input ports

Additional control logic surrounding U802 consists of:

- (1) D/A CONVERTER U801. This IC is used to generate precision analog voltages for transmitter power control, deviation adjustment, and reference oscillator frequency warp.
- (2) CUSTOM GATE ARRAY U803. This device expands the input/output capabilities of the control logic. U802 and U803 exchange information which tells the microcomputer the input port status and the desired state of the output ports. Used in expanded logic boards only.
- (3) EPROM U804. This is an Erasable Programmable Read Only Memory, whose function is to store the microcomputer's operating program. Used in expanded logic boards only.
- (4) EEPROM U805. This is an Erasable Programmable Read Only Memory, which acts as the radio's code plug. It supplements the capability of the EPROM contained within U802, storing additional operating information pertinent to a particular radio, such as operating frequencies, signaling codes, scan lists, time-out timer, programmable I/O assignments, and other special functions. Used in expanded logic boards only.
- (5) SRAM U806. This Static Random Access Memory is used for "scratch pad" operations. Used in expanded logic boards only.

In masked logic boards, the microcomputer's operating program is permanently written or "masked" within the microcomputer. Included in U802 is an EEPROM memory which stores channel, signaling, and scan list information, similar in function to U805 but with less

storage capability.

2.2.1 Microcomputer Start-Up Routine

The microcomputer is operational after the RESET line is released by U402 at turn-on. Y801, the crystal oscillator, should be stable at this point. Y801's frequency is divided by four by U802 to produce the E-CLOCK (1.944 MHz, at U802-5) which is the data clock for microcomputer and, in expanded logic boards, gate array U803. The microcomputer then executes a self-test routine and generates an error tone if a failure is detected. Q807 shifts the crystal frequency very slightly by introducing network L801/C831 when Q807 is off. This can be used to remove an on-channel self-quieting signal which is a harmonic of the crystal, if necessary.

2.2.2 Microcomputer Operation (Expanded Logic)

In expanded logic boards, a successful self test of the control logic will activate the multiplexed address/data bus. The microcomputer has an eight bit address/data bus and an eight bit address-only bus. These bus lines are connected to gate array U803 for I/O port information, and to the external memory IC's to send and receive information.

The custom gate array must de-multiplex the lower order address byte from the address/data bus (AD0-AD7) in order to address a particular function or memory location.

The microcomputer puts the address information on AD0-AD7 and the information is then passed to U803. The address strobe "AS" is pulsed low and the byte is latched. The de-multiplexed address byte A0-A7 is then available on U803. The bus is now ready for the transmission of data. The higher order address byte A8-A15 is not multiplexed and is readily available at the microcomputer U802.

2.2.3 Reading or Writing in Memory (Expanded Logic)

In expanded logic boards, the specified memory IC must first be enabled before a read/write operation can take place. Each memory IC has its own chip select line. EPROM SEL originates at U803-13, EEPROM SEL at U803-14, and SRAM SEL at U803-15. The lines are normally logic high; a specific IC is selected when the appropriate line is pulsed low.

The R/W line from U803-16 determines if data is being read (logic high) or written (logic low). EPROM U804 is a read-only memory and does not require a R/W input.

The output enable line "OE", when pulsed low, will enable the tri-state output gates to pass the contents of the desired address out onto the A/D bus.

2.2.4 Programmable I/O's

In masked logic boards, the function of J3-14 is programmable by the placement of push-on jumper

JU809. In the "REMOTE" position, J3-14 provides the hook function for a remote desk set. When pulled low, the radio is forced "off-hook" or into a monitor condition. In the "PA" position, J3-14 provides the public address enable function; when pulled low, transmitter PTT is inhibited.

In expanded logic boards, pins 8, 12 and 14 are software-programmable I/O's, pins 6 and 9 are software-programmable inputs, and pin 4 is a software-programmable output. If, for example, J3-14 is used as an input, U803-39 will be logic low, keeping Q814 off. When an accessory pulls J3-14 low, Q813 will turn off, and the resulting logic high at its collector will be read by U803-24. If J3-14 is programmed as an output, the signal provided by U803-39 will turn Q814 on or off as needed, supplying either an active low or a logic high (pulled up by R901, 4.7k) to the accessory. By moving JU808 from its normal PROG I/O position to the SCI + position, J3-12 can be used as an SCI programming line, electrically connected via J8-9 to the SCI + pin on the microphone connector (pin 7).

2.3 RECEIVER AUDIO CIRCUITRY

2.3.1 Voice Path

Detector audio from the RF board is routed via J6-3 to U551A. A series resistor on the RF board, R62, is chosen to provide an additional 6 dB of receiver audio gain in 12.5 kHz channel spacing models, where full system deviation is one half of that used for 25/30 kHz channel spacing. The gain of U551A is chosen so that supply-rail limiting occurs at 20% above full system deviation. This limits the amplitude of impulse-type ignition noise. Noise above 3 kHz is attenuated by a 3-pole low pass filter (U551B) whose Bessel-Thompson characteristic is chosen to minimize ringing due to impulse-type noise. Following is a 5-pole biquadratic 300 Hz high-pass filter (U552A and B) which attenuates subaudible signaling tones such as PL and DPL. This is followed by de-emphasis amplifier U553A, mute gate Q551 and summing amplifier U553B which combines the receive audio signal with alert tones generated by the microcomputer at U802-29 and filtered by C566 and C567. The output of U553B is routed to the volume control via J8-1, from the volume control via J8-2 to the input of the audio power amplifier, U501.

The audio power amplifier is a BTL (bridge-tied load) configuration providing 7.5 watts rms into an external 8 ohm speaker. Both sides of the speaker are driven with out-of-phase signals, therefore neither side of the speaker can be grounded. The outputs are internally protected against accidental short circuits to supply or ground. The internal speaker has a 22 ohm impedance which limits the power delivered to it to 3 watts, which is within its rating. The audio power amplifier is turned on when a sense voltage greater than 8 volts DC is applied to pin 8. This is obtained from SW B + via R501. When no audio output is required, U501 is turned off by saturating transistor Q501, providing 0 volts to U451 pin 8. This allows muting of the audio power amplifier. When the radio is turned

off, SW B + is not present, so there is no source of voltage to pin 8 via R501, keeping U501 off. When muted (pin 8 low), U501 draws no current from the UNSW B + source. Capacitor C504 controls the turn on and turn off timing of the power amplifier to minimize transients. C501 and C502 provide low and high frequency filtering respectively.

When any front panel button is pressed, a beep is heard in the speaker. This is produced by the microcomputer-generated alert tone applied to stage U553B, as discussed above. U501 is enabled by turning off Q501, however mute gate Q551 remains muted so that the beep is heard but noise or signals from the receiver are not. Alert tones are also used by various signaling systems, or for error tones during self-test.

Receiver audio is available at the accessory connector J3-11. Depending on the position of push-on jumper JU551, audio may be either de-emphasized, filtered and muted, derived from the output of U553B, or flat and unmuted, derived from the output of U551A in masked logic boards or from buffer U651B in expanded logic boards.

2.3.2 Data Path

Receiver audio is also used for decoding of signaling tones or codes. There are two general classifications of the types of data involved. High-speed data refers to data which occupies the voice range of frequencies (between 300 and 3000 Hz, although it can also occupy the entire range from less than 1 Hz to 3000 Hz). This data is not transmitted simultaneously with voice. The other type is low-speed data, which is contained to frequencies below 300 Hz, generally at reduced deviation levels, and may be transmitted simultaneously with voice. MDC1200 and Select 5 are examples of high-speed data; PL and DPL are examples of low-speed data.

Low speed data is obtained from U551B-7, which contains frequencies between 0.6 Hz and 3000 Hz. It is buffered by U602A and filtered by U603A and U603B in masked logic boards, or U602B and U603A in expanded logic boards. These form a 5-pole biquadratic low pass filter, attenuating all signals above 250 Hz. This filter prevents voice from interfering with low-speed data detection. This is fed to a center-slicer (U601B in masked, U603B in expanded) which converts the tone or data into a symmetrical square wave which can be decoded by the microcomputer. The center slicer tracks out near-DC offsets to maintain waveform symmetry. In expanded boards, U603B is an opamp rather than a comparator, and transistor Q601 is used to provide level shifting to a 0-to-5V logic level.

High speed data can be obtained from either U551B-7, the same point as for low-speed data, or from U552B-7, which only contains frequencies between 300 and 3000 Hz. If the type of data does not contain information below 300 Hz, the use of additional 300 Hz high-pass filtering improves detector sensitivity. No additional filtering is required, only that the signal is squared up by

center-slicer U601A before being applied to the microcomputer for decoding.

2.4 TRANSMITTER AUDIO CIRCUITRY

2.4.1 Voice Path

Microphone audio is routed from the front panel mic jack via J8-14, or from accessory connector J3-2, to the mic mute gate Q651. DC bias is applied to operate the transistor amplifier within the microphone. Q651 is controlled by Q652 and mutes the microphone audio path during receive mode or during transmission of high-speed signaling or data. When low mic gain (80 mV rms for 60% deviation) is selected by JU651, the signal is pre-emphasized by C652 and R655; for high-gain (40 mV rms), by C667 and R647. Supply rail limiting by U651A prevents over-deviation.

The signal is then routed to the RF board reference oscillator modulation input via J6-13, and, via buffer U652A, to voltage controlled attenuator U652. Deviation is adjusted by programming the DC output voltage of D/A converter U801-6. This allows electronic adjustment of deviation, compensation for sensitivity variations across the operating frequency band, and choice of full system voice deviation on non-PL or DPL channels, or reduced voice deviation on channels with PL or DPL. The output of attenuator U653 is routed through U652B, a 3-pole biquadratic 3000 Hz low-pass "splatter" filter, before being applied to the RF board as VCO modulation via J6-10.

Radios used in 12.5 kHz channel spacing systems require full deviation of 2.5 kHz, instead of 5 kHz for 25/30 kHz systems. This reduction is accomplished by resistor values on the RF board surrounding the VCO MOD and REF MOD adjust posts.

2.4.2 Data Path

High speed data is generated by microcomputer outputs U802-30 and 31 which are summed by opamp U602B (masked) or U701A (expanded). The ratio of R701 and R702, and the relative timing of the transitions of the two microcomputer outputs, allow low-distortion simulated sinewaves to be generated. The opamp output is routed to the input of limiter U651A, where it is summed with pre-emphasized mic audio and with audio from accessories connected via J3-5. Neither the high speed data or the accessory audio input is pre-emphasized. The remainder of the audio path to the modulator is the same as for the voice signal path.

Low speed data is generated by microcomputer outputs U802-27 and 28 which are summed by opamp U651B (masked) or U701B (expanded). The ratio of R706 and R707 allow low-distortion simulated sinewaves to be generated. The opamp is configured as a 3-pole biquadratic low pass filter to remove any distortion components of the low speed data signal above 300 Hz which would fall within the voice range. This audio is resistively summed with the output of the limiter U651A. In this

manner, limiting on voice peaks will not affect the continuous low speed data transmission. The summed audio is then routed to the REF MOD input of the RF board via J6-13, and to the voltage controlled attenuator, splatter filter, and VCO MOD input of the RF board (J6-10), following the same path as voice signals.

2.5 TRANSMITTER POWER CONTROL CIRCUITRY

2.5.1 Control Line Functions

As discussed earlier, all DC operating voltage for the radio originates from the RF power amplifier via J7-5 (UNSW B+). In addition, J7 receives DC control voltages from, and supplied DC control voltages to the RF power amplifier circuitry.

In the transmit mode, Q455 conducts, supplying 9.6T (keyed 9.6V DC) via J7-1 to the antenna switch and providing bias (and collector voltage, in UHF models) for the first transmitter stage.

Controlled B+ is supplied via J7-2 to the collector of the first (VHF) or second (UHF) transmitter stage. As this voltage varies over the range of 3 to 12.5V DC, transmitter output power is varied over the range of 10 to 25 watts.

A small-value (.05 ohm) resistor is placed in series with the DC supply to the RF final amplifier, and the voltage across this resistor is measured via the current sense high (J7-3) and low (J7-4) lines.

The temperature of the final RF amplifier is monitored by a thermistor mounted next to it. The thermistor is part of a voltage divider network whose output voltage is routed, via J7-6, to an A/D input of the microcomputer, U802-49.

2.5.2 Power Control Operation

Power is programmed electronically during radio tune-up and may be different for each channel. The software varies the DC output voltages of D/A converters U801-2 and U801-4 (two D/A's are summed for increased resolution) and applied to the (+) input of opamp U451A. As D/A voltage increases, U451A-1 output voltage increases, which causes greater conduction in Q453 and Q452, thus increasing the control voltage and RF power output. The values of R810, R811, R462 and R463 reduce the D/A output voltage range (0 to 9V DC) to the required 4V to 6V DC range at U451A-3.

If the DC current of the final RF amplifier increases excessively due to, for example, an antenna system fault, the increased voltage drop across the series resistor will be sensed by U451B, causing the current through Q454 to increase until the two inputs of U451B are again equal (the collector resistor of Q454 is on the RF power amplifier board since its value is optimized for different power amplifiers). The increase in Q454 current raises its emitter voltage which is applied to the (-) input of U451A. This is in a direction to reduce the output voltage of

U451A-1, reducing conduction in Q453 and Q452, lowering the controlled B+ voltage to counteract the excessive current condition.

Excessive RF final amplifier temperature causes an increase in the THERMAL DC voltage at U802-49. The microcomputer reduces power via the D/A converter to achieve a safe equilibrium.

Under any circumstance, controlled B+ is prevented from exceeding a pre-programmed DC voltage. The voltage is divided by R471 and R472 and monitored by microcomputer A/D input U802-45 every 17 msec. If voltage exceeds the maximum allowable, the DAC is decremented one step, and this process is repeated as needed.

3. RF Power Amplifier

3.1 10-25 WATT VHF POWER AMPLIFIER

The 10-25 watt VHF power amplifier is designed to cover the range of 146-174 MHz. It consists of three basic circuits:

- Power amplifier
- Antenna switch
- Harmonic filter

The power amplifier consists of three stages. The first stage, Q2310, operates in Class A with base bias supplied by the 9.6T source. The collector voltage is supplied from controlled B+. The output level of this stage is varied by changes in the controlled B+ voltage.

The second stage, Q2320, is operated in Class C. Collector voltage is supplied by UNSW B+. This stage delivers up to 3 watts output.

The third stage, Q2330, is the Class C RF final power amplifier. It can output in excess of 30 watts with 3 watts input power. Collector current is monitored by the power control circuit by measuring the voltage drop across a .05 ohm resistor, R2371, placed in series with the collector DC supply lead.

The antenna switch consists of two pin diodes, CR2350 and CR2351. L2353 is parallel-resonant with the off capacitance of CR2350, increasing its isolation when turned off. C2354 is a DC block. L2352 and C2352, combined with the "on" inductance of CR2351, form a series resonant circuit to lower the shunt impedance presented by CR2351 when it is turned on.

In the receive mode, both diodes are off. Signals applied at the antenna jack J1 are routed, via the harmonic filter, through network L2351, C2351 and C2353 to the receiver input. In the transmit mode, 9.6T is present and both diodes are forward-biased into conduction. The transmitter RF from Q2330 is routed through CR2350, and via the harmonic filter to the antenna jack. CR2351 conducts, shunting RF power and preventing it from

reaching the receiver. L2351 is selected to appear as a 1/4 wave at VHF, so that the low impedance of CR2351 appears as a high impedance at the junction of CR2350 and the harmonic filter input.

The harmonic filter is a nine pole 0.1 dB ripple Chebychev low pass filter with a 3 dB frequency of approximately 205 MHz and less than 1 dB insertion loss in the passband.

3.2 10-25 WATT UHF POWER AMPLIFIER

The 10-25 watt UHF power amplifier is designed to cover the range of 449-470 MHz and has four stages. The first stage, Q2610, operates in Class A with base bias from 9.6T. It provides 11.8 dB of gain and an output of 300 milliwatts.

The second stage, Q2620, has a nominal gain of 8.2 dB and power output of up to 2 watts. The output of this stage is adjusted by the controlled B+ voltage which supplies its collector.

The third stage, Q2630, operates in Class C with 8.1 dB gain and a power output of up to 13 watts. Collector voltage is directly from UNSW B+.

The fourth stage, Q2640, is the final RF power amplifier, which operates Class C directly from UNSW B+. It provides up to 30 watts output. Collector current is monitored by the power control circuit by measuring the voltage drop across a .05 ohm resistor, R2670, in series with the collector DC supply lead.

The antenna switch consists of two pin diodes, CR2650 and CR2651. L2652 and C2651-2, combined with the "on" inductance of CR2651, form a series resonant circuit to lower the shunt impedance presented by CR2651 when it is turned on. In the receive mode, both diodes are off. Signals applied at the antenna jack J1 are routed, via the harmonic filter, through network L2651, C2652 and C2653 to the receiver input. In the transmit mode, 9.6T is present and both diodes are forward-biased into conduction. The transmitter RF from Q2640 is routed through CR2650, and via the harmonic filter to the antenna jack. CR2651 conducts, shunting RF power and preventing it from reaching the receiver. L2651 is selected to appear as a 1/4 wave at UHF, so that the low impedance of CR2651 appears as a high impedance at the junction of CR2650 and the harmonic filter input.

The harmonic filter is a seven pole 0.1 dB ripple Chebychev low pass filter with a 3 dB frequency of approximately 500 MHz and less than 1 dB insertion loss in the passband.

4. Front Panel Boards

The front panel housing itself contains two circuit boards, the Display Board and the Volume/Mic Board.

A third board, the Front Panel Filter Board, is located on the front of the radio chassis.

4.1 DISPLAY BOARD

The Display Board consists of three colored indicator LED's (DS1101-3), three green LED's which illuminate the keypad buttons (DS1105-7), a dual 7-segment LED display (DS1104), a display driver IC (U1101) and five momentary pushbuttons (SW1101-5).

After power up, the microcomputer loads U1101 with information using the SERIAL DATA (P9-10), SERIAL CLOCK (P9-11), and DISPLAY ENABLE (P9-2) lines. This data tells U1101 which segments and indicator LED's to illuminate. U1101 is a shift register latch. Its outputs are active low when a particular LED is to be illuminated, or open circuit when an LED is to remain off. The anodes of all LED indicators or segments are connected to the +5V DC source. The three keypad illumination LED's are lit at all times when +5V is present.

SW1101 through SW1105 are normally-open momentary pushbuttons. When pressed, the conductive ink on the back side of the rubber pushbutton comes in contact with the exposed circuit pattern on the display circuit board, providing a low resistance (less than 100 ohms) path to ground.

4.2 VOL/MIC BOARD

The VOL/MIC circuit board provides mounting and

electrical connection to the microphone jack J11 and the on-off/volume control R9002. Connections are made to the logic board via P8. This cable/connector assembly also contains the two wires which route receiver audio to the internal 22 ohm speaker mounted in the front panel.

A 10 ohm resistor, R9001, is located between the CCW side of the volume control element and ground. At minimum volume setting, this maintains the attenuation at no greater than 46 dB, to avoid missing a message if the volume control is inadvertently turned to minimum.

4.3 FRONT PANEL FILTER BOARD

The front panel filter board is mounted to the front of the radio chassis. The pins of logic board connectors J8 and J9 pass through this board and are soldered to it. This board allows capacitive bypassing of all signal leads leaving the front of the radio chassis. This, combined with the shielding covers over the RF board, logic board and RF power amplifier, reduces the levels of cabinet radiation to extremely low levels.

In addition, the front panel filter board also provides protection against electrostatic discharge into front panel controls or indicators. Zener diodes are installed on any lines which are susceptible to damage from excessive static voltage transients, limiting voltage excursions to +27V or -0.7V DC.

Jumper-Selectable Options

There are several push-on jumpers, located on the logic board, which allow the operation of the radio to be customized to specific applications. The function of each jumper is explained below.

Note that JU808 is only present in 4-layer "expanded" logic boards, and JU809 is only present in 2-layer "masked" logic boards.

The standard position of each jumper, as shipped from the factory, is indicated in bold.

JU551	POSITION (A)	The receiver audio applied to the accessories connector J3 pin 11 is flat (not de-emphasized) and unmuted.
	POSITION (B)	The receiver audio applied to the accessories connector J3 pin 11 is de-emphasized and muted. Muting is controlled by the RX MUTE output from the microcomputer, as determined by carrier or tone squelch status.
JU601	POSITION (A)	The high-speed receive data path to the microcomputer is filtered to remove audio information below 300 Hz. This is used when decoding signaling data or tones which do not contain low frequency information.
	POSITION (B)	The high-speed receive data path to the microcomputer is essentially flat over the frequency range of less than 1 Hz to 3 kHz. This is used when decoding signaling data which includes very low frequency components.
JU651	POSITION (A)	Selects low microphone audio sensitivity, which is 80 mV rms for 60% of full system deviation.
	POSITION (B)	Selects high microphone audio sensitivity, which is 40 mV rms for 60% of full system deviation. This position is not recommended in applications where high ambient noise is present.
JU808	POSITION (A)	Pin 12 of accessories connector J3 functions as a programmable I/O (input or output) as determined by the RSS.
	POSITION (B)	Pin 12 of accessories connector J3 functions as the SCI + programming line. It is connected directly to the SCI + line on microphone connector J11.
JU809	POSITION (A)	Allows the use of a remote desk set which is connected to accessories connector J3. Pin 14 functions as the HOOK line. When pulled low, the radio is forced into the monitor (off-hook) position. Note that this is the opposite polarity of the HOOK function on the microphone connector J11.
	POSITION (B)	Allows the use of an HLN3145 Public Address system. Pin 14 of accessories connector J3 functions as the PA ENABLE line. In the public address mode this line is pulled low, inhibiting transmit PTT operation, but leaving all other radio functions unchanged.

Note: When a R*I*C*K Repeater adapter is used, the push-on jumper JU809 must be removed entirely.

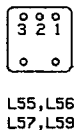
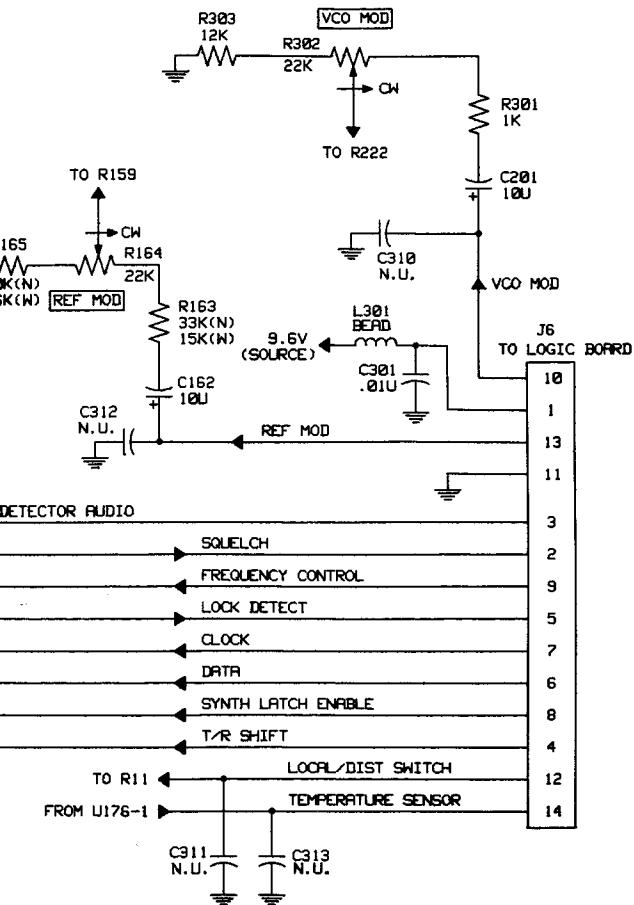

NOTES:

1. UNLESS OTHERWISE INDICATED, RESISTOR VALUES ARE IN OHMS, CAPACITOR VALUES ARE IN PICOFARADS, INDUCTOR VALUES ARE IN MICROHENRIES.
2. NON-POLARIZED CAPACITORS ARE CHIP-TYPE UNLESS OTHERWISE INDICATED.
3. POLARIZED CAPACITORS ARE ALUMINUM ELECTROLYTIC UNLESS OTHERWISE INDICATED.
4. DC VOLTAGES ARE MEASURED WITH A HIGH IMPEDANCE (10 MEGOHM) DC VOLTMETER.
5. AC RF VOLTAGES ARE MEASURED WITH A HIGH IMPEDANCE RF MILLIVOLTMETER.
6. ALL VOLTAGE MEASUREMENTS ARE IN THE RECEIVE MODE UNLESS INDICATED AS FOLLOWS:
(R) RECEIVE MODE
(T) TRANSMIT MODE
7. MEASURED IN THE RECEIVE MODE WITH AN ON-CHANNEL UNMODULATED SIGNAL AT A LEVEL OF -20 DBM.
8. MEASURED IN THE RECEIVE MODE WITH AN ON-CHANNEL SIGNAL AT A LEVEL OF -20 DBM, MODULATED WITH 1KHZ AT 3KHZ DEVIATION. MEASURED WITH AN AC RMS VOLTMETER.
9. COMPONENT VALUES MARKED (N) ARE USED IN 12.5 KHZ CHANNEL SPACING MODELS. VALUES MARKED (W) ARE USED IN 20/25/30 KHZ CHANNEL SPACING MODELS.

Schematic Diagrams for HLD8029A and HLD8031A VHF RF Boards

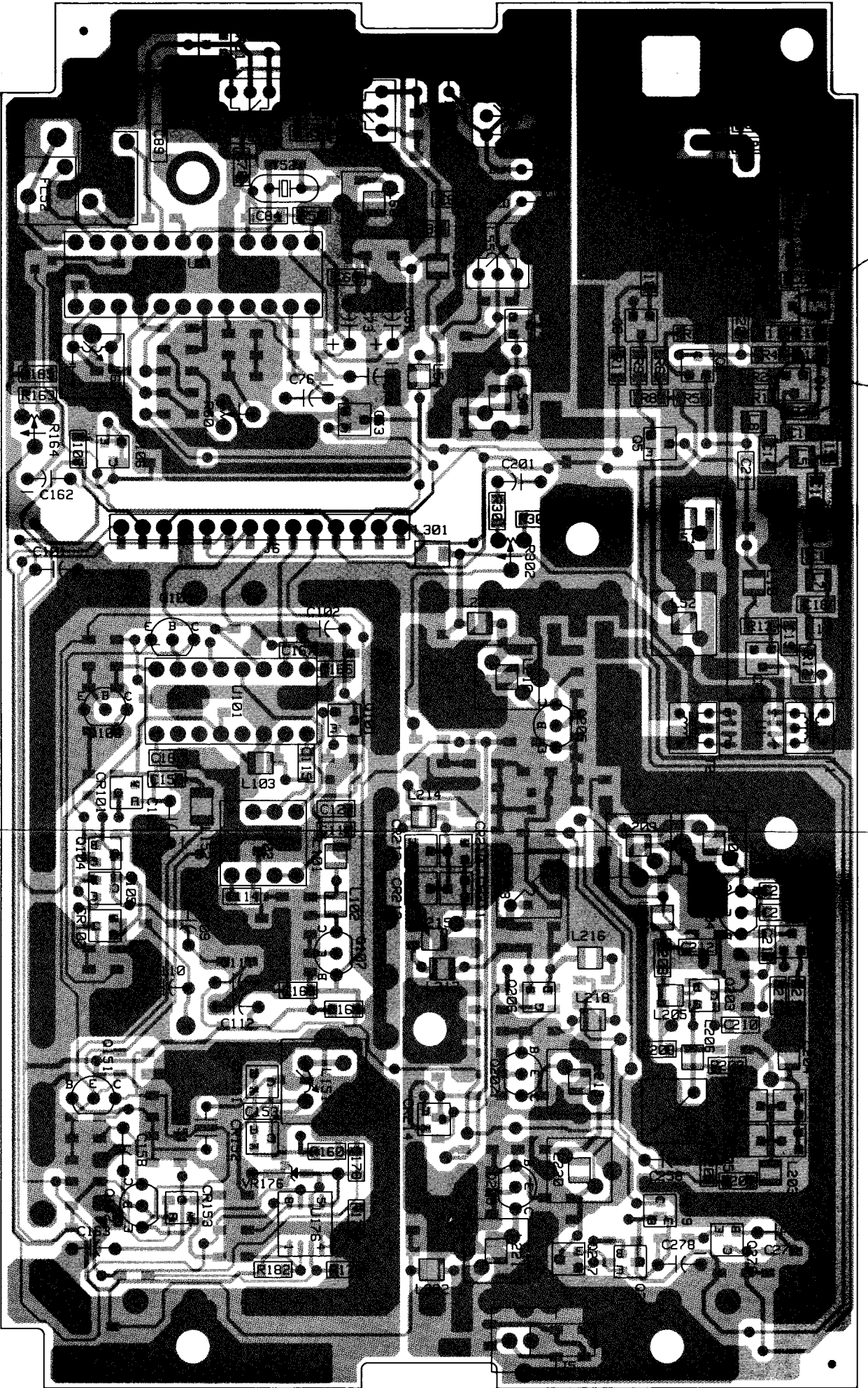

component side

COMPONENT SIDE (Gray)
 SOLDER SIDE (Pink)
 OVERLAY (White)

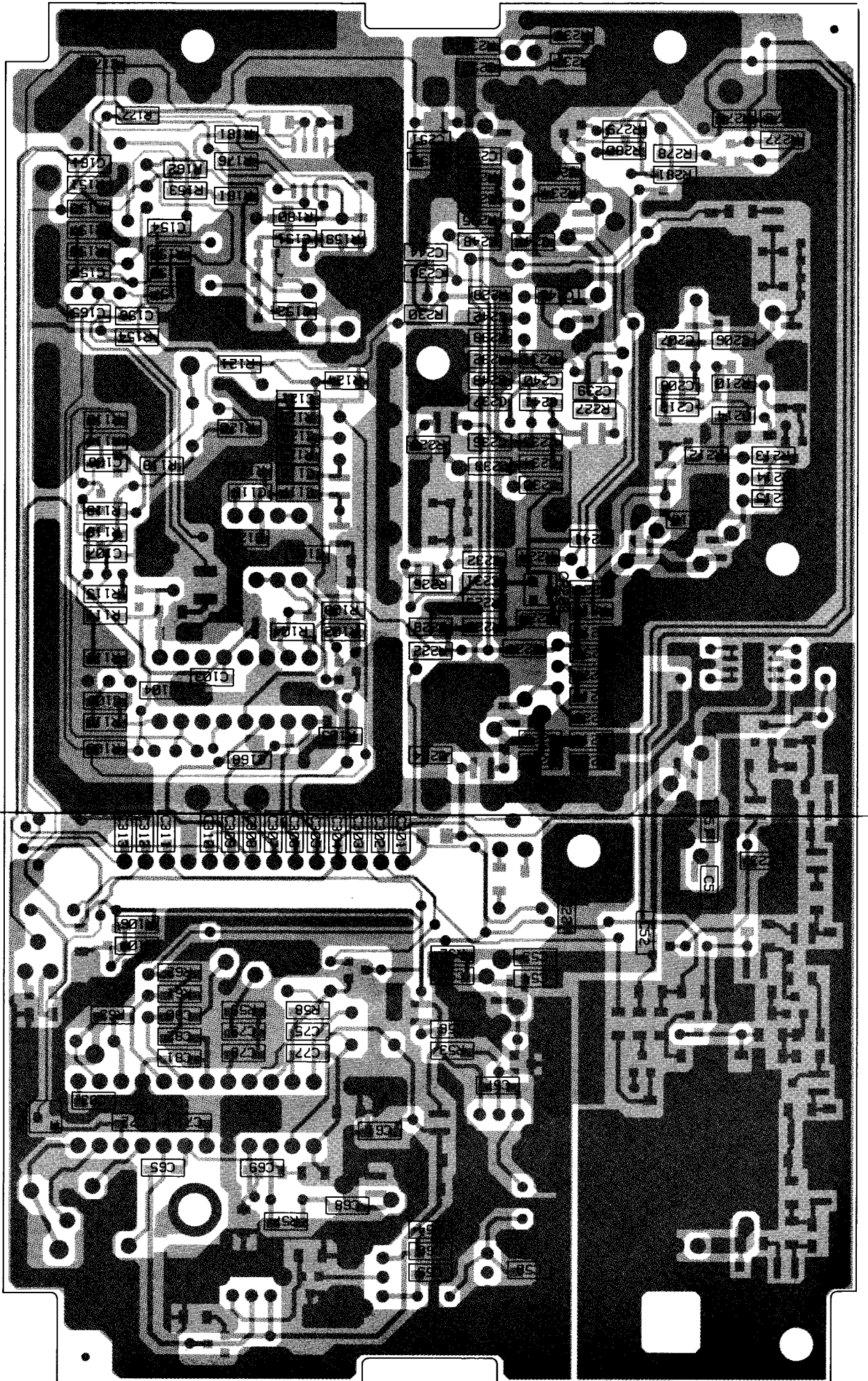

COMPONENT SIDE (Gray)

SOLDER SIDE (Pink)

OVERLAY

solder side

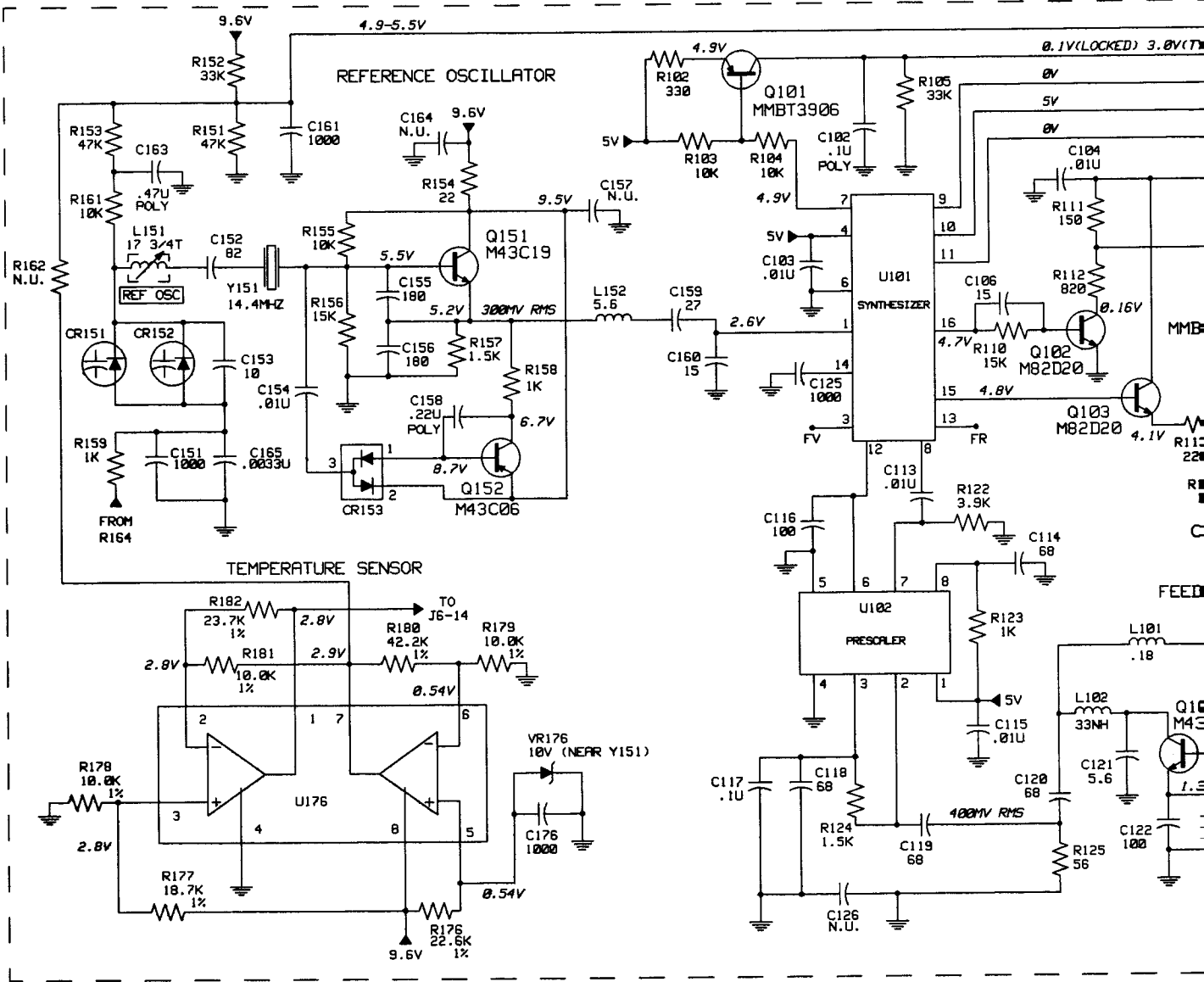
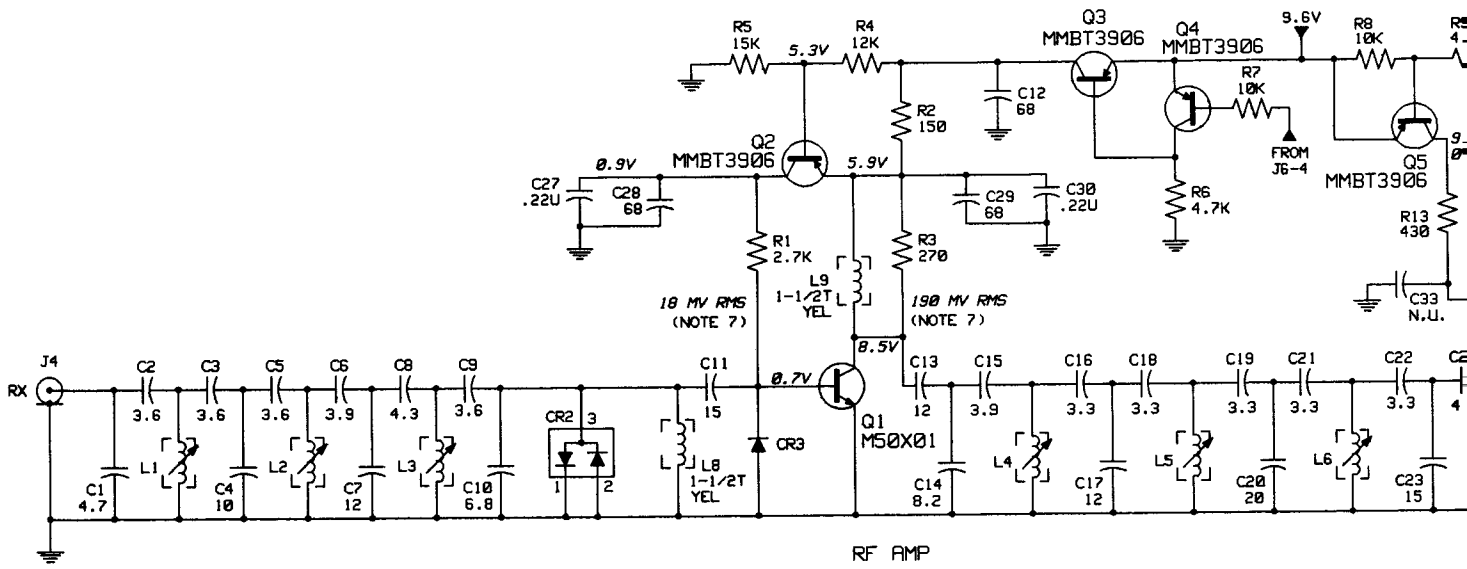

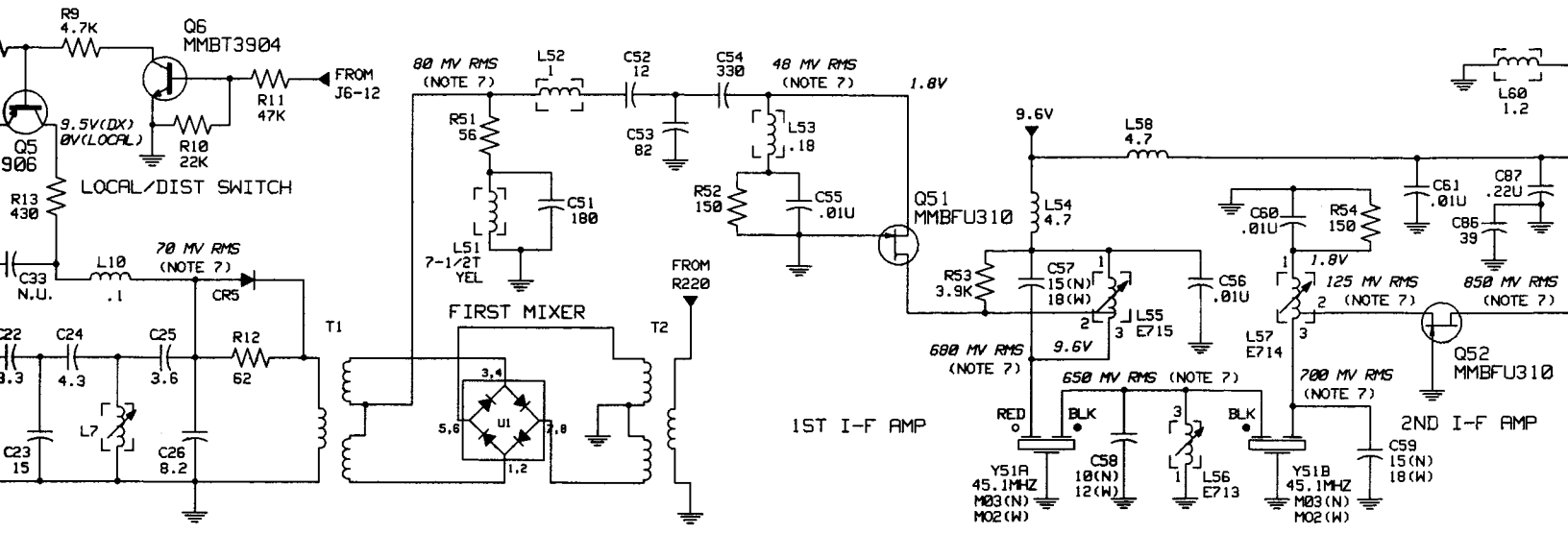

3.0V(TYP)(UNLOCKED)

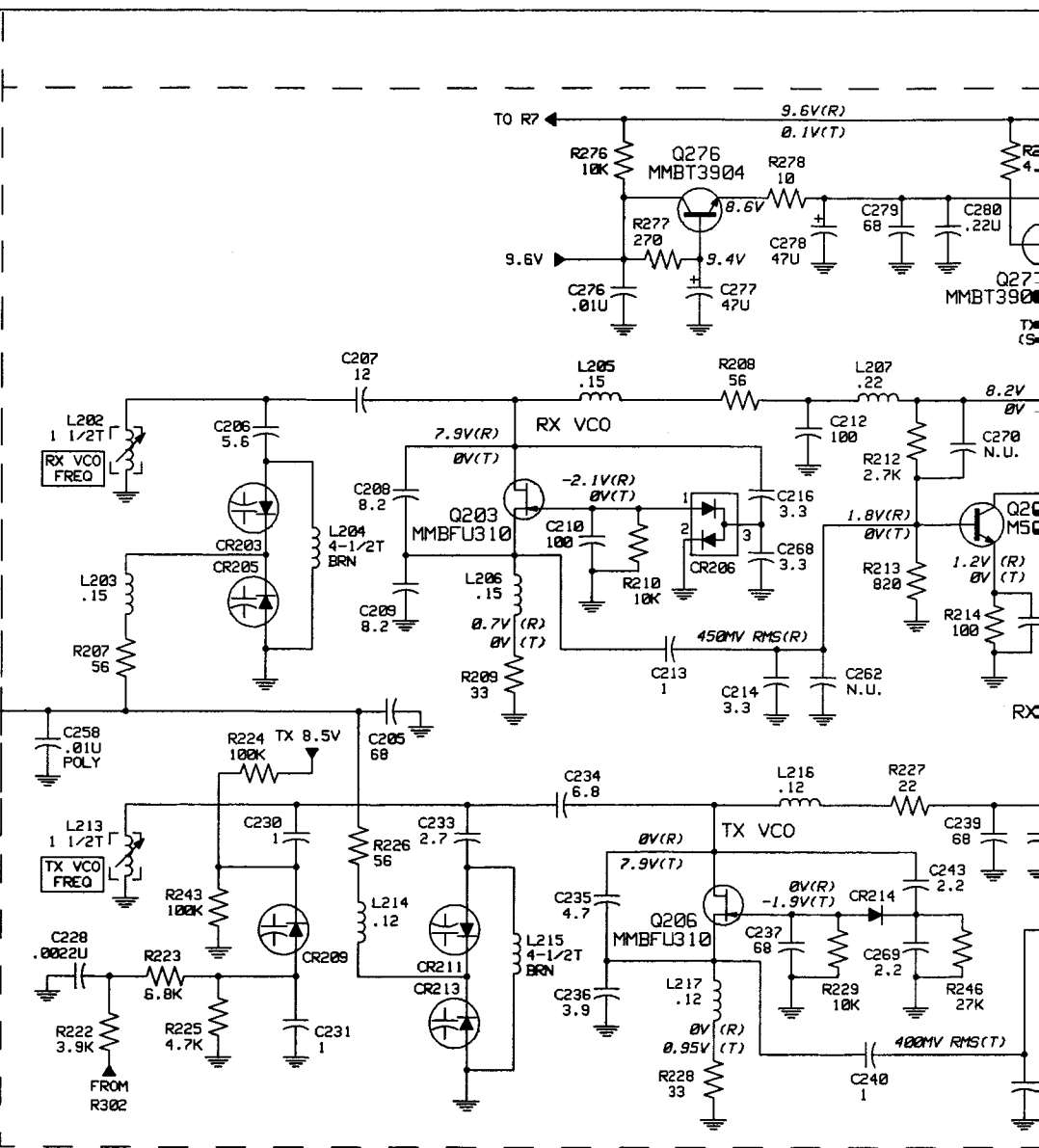
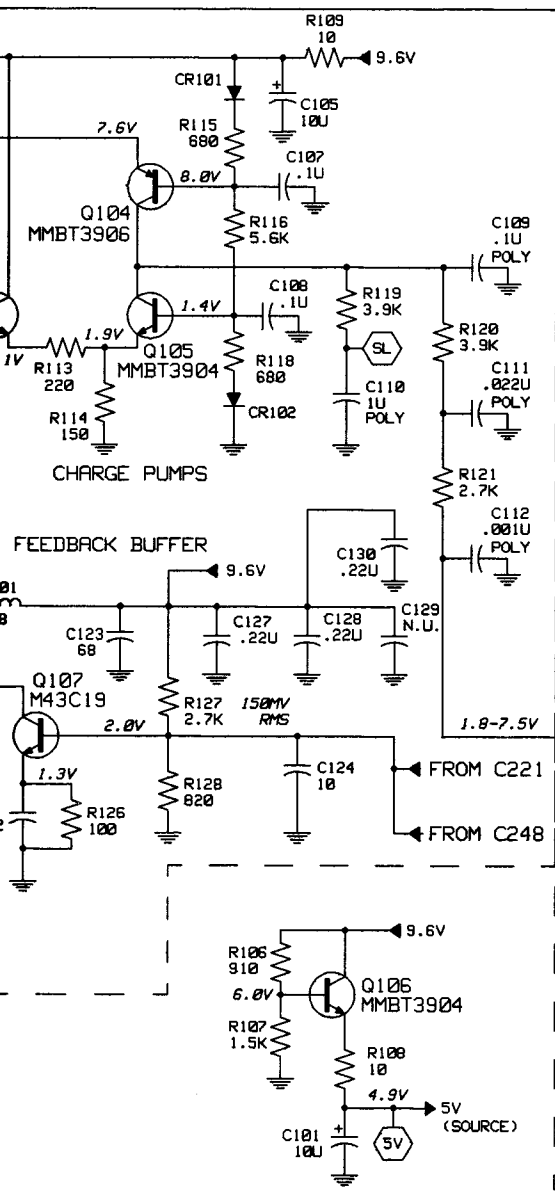

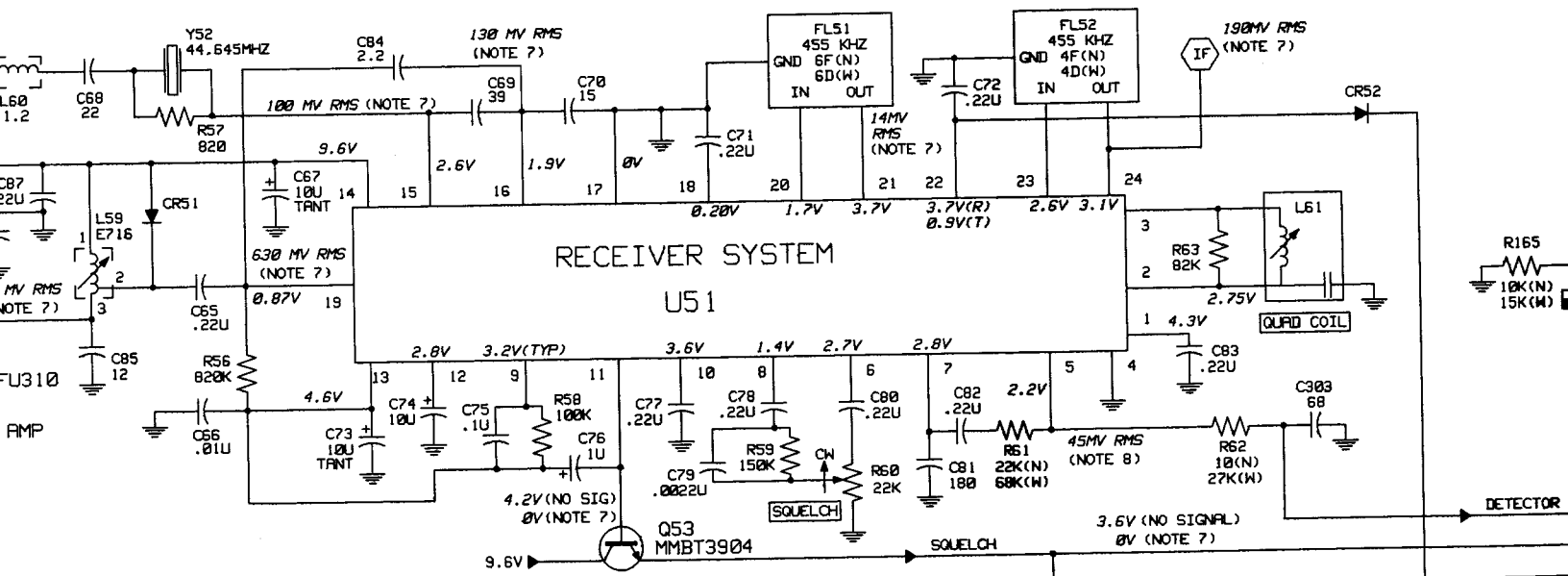

FREQUENCY CONTROL
 LOCK DETECT
 CLOCK
 DATA
 SYNTH LATCH ENABLE
 T/R SHIFT

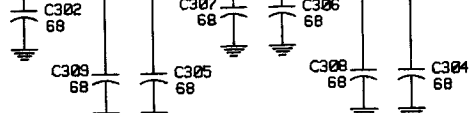
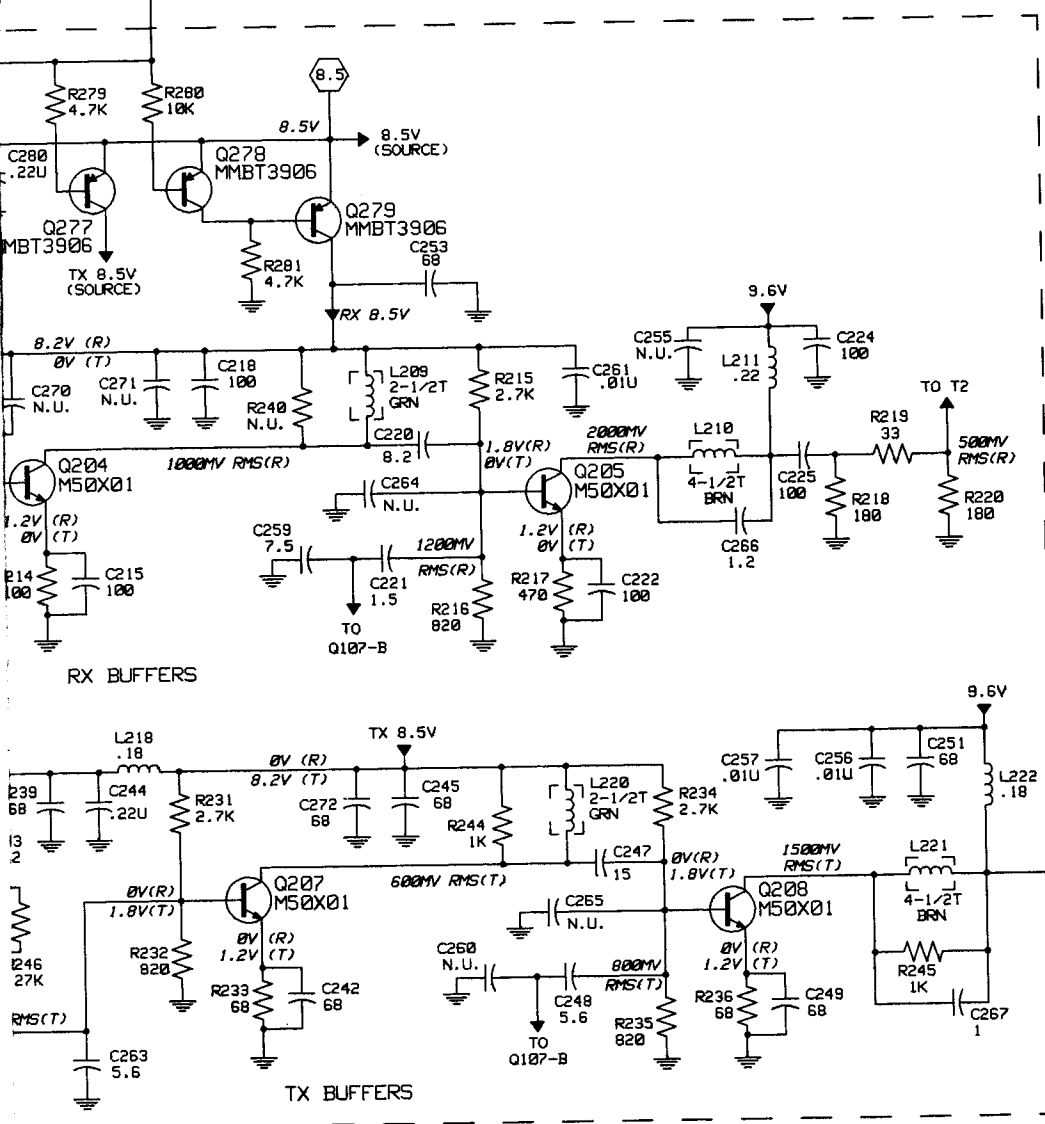

ALL VIEWS ARE FROM TOP OF PART

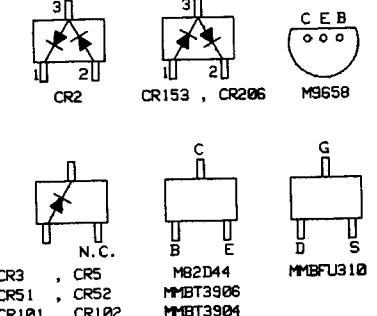

- CR3, CR5
- CR51, CR52
- CR101, CR102
- CR151, CR152
- CR203, CR205
- CR209, CR211
- CR213, CR214

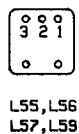
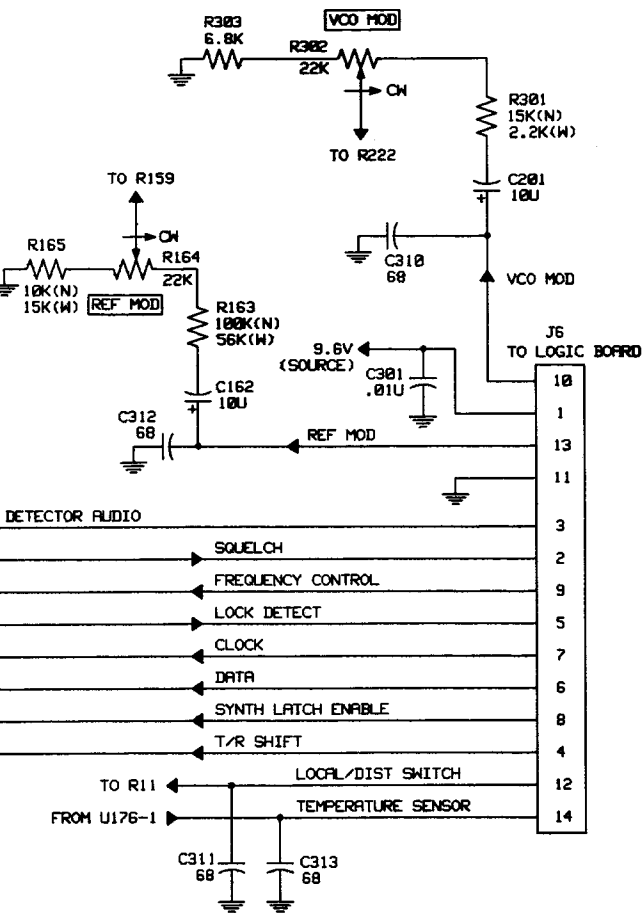

NOTES:

1. UNLESS OTHERWISE INDICATED, RESISTOR VALUES ARE IN OHMS, CAPACITOR VALUES ARE IN PICOFARADS, INDUCTOR VALUES ARE IN MICROHENRIES.
2. NON-POLARIZED CAPACITORS ARE CHIP-TYPE UNLESS OTHERWISE INDICATED.
3. POLARIZED CAPACITORS ARE ALUMINUM ELECTROLYTIC UNLESS OTHERWISE INDICATED.
4. DC VOLTAGES ARE MEASURED WITH A HIGH IMPEDANCE (10 MEGOHM) DC VOLTMETER.
5. AC RF VOLTAGES ARE MEASURED WITH A HIGH IMPEDANCE RF MILLIVOLTMETER.
6. ALL VOLTAGE MEASUREMENTS ARE IN THE RECEIVE MODE UNLESS INDICATED AS FOLLOWS:
(R) RECEIVE MODE
(T) TRANSMIT MODE
7. MEASURED IN THE RECEIVE MODE WITH AN ON-CHANNEL UNMODULATED SIGNAL AT A LEVEL OF -20 DBM.
8. MEASURED IN THE RECEIVE MODE WITH AN ON-CHANNEL SIGNAL AT A LEVEL OF -20 DBM, MODULATED WITH 1KHZ AT 3KHZ DEVIATION. MEASURED WITH AN AC RMS VOLTMETER.
9. COMPONENT VALUES MARKED (N) ARE USED IN 12.5 KHZ CHANNEL SPACING MODELS. VALUES MARKED (W) ARE USED IN 25 KHZ CHANNEL SPACING MODELS.

Schematic Diagram for HLE8030A and HLE8032A UHF RF Boards

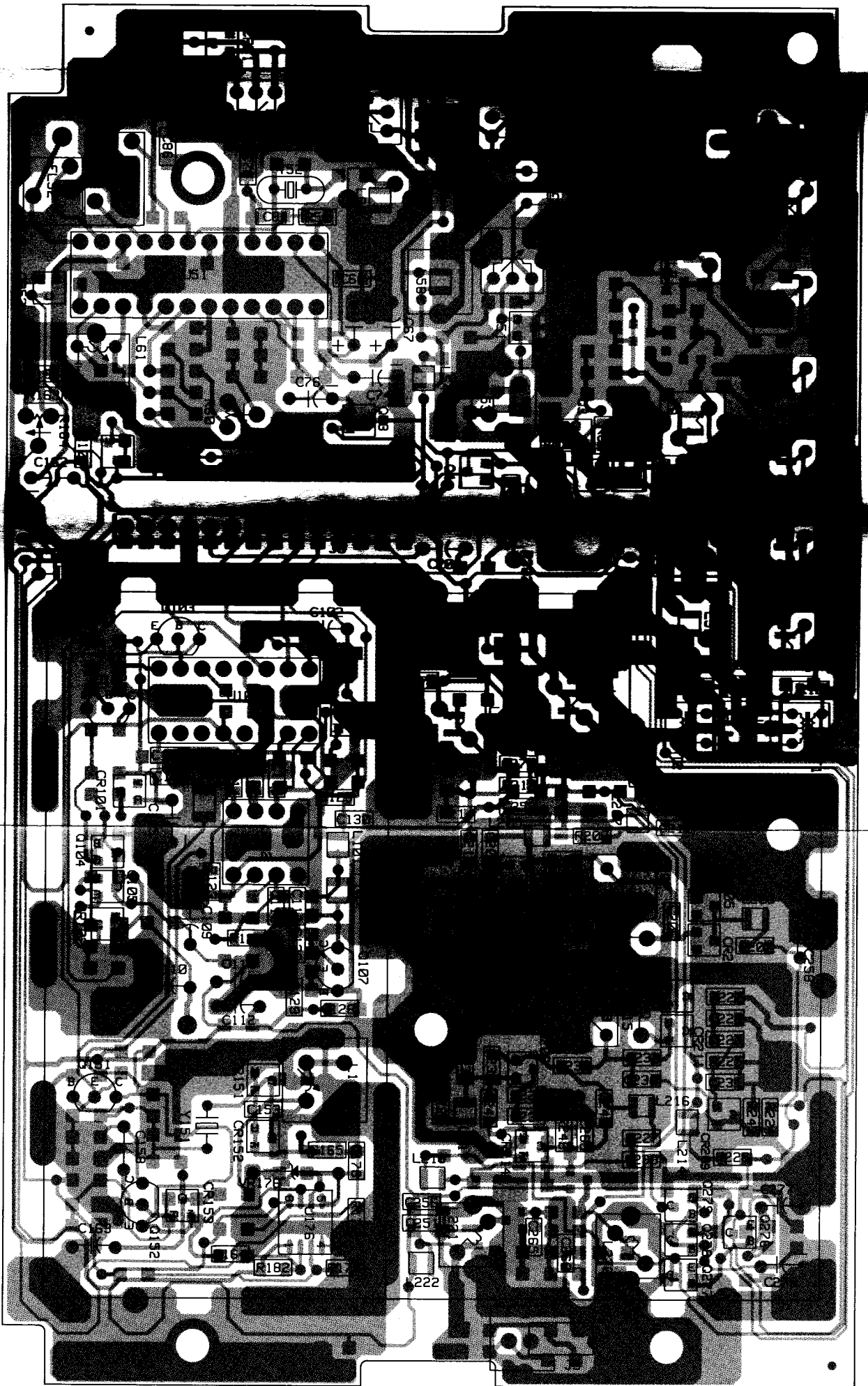

COMPON

COMPONENT SIDE (Gray)

SOLDER SIDE (Pink)

OVERLAY

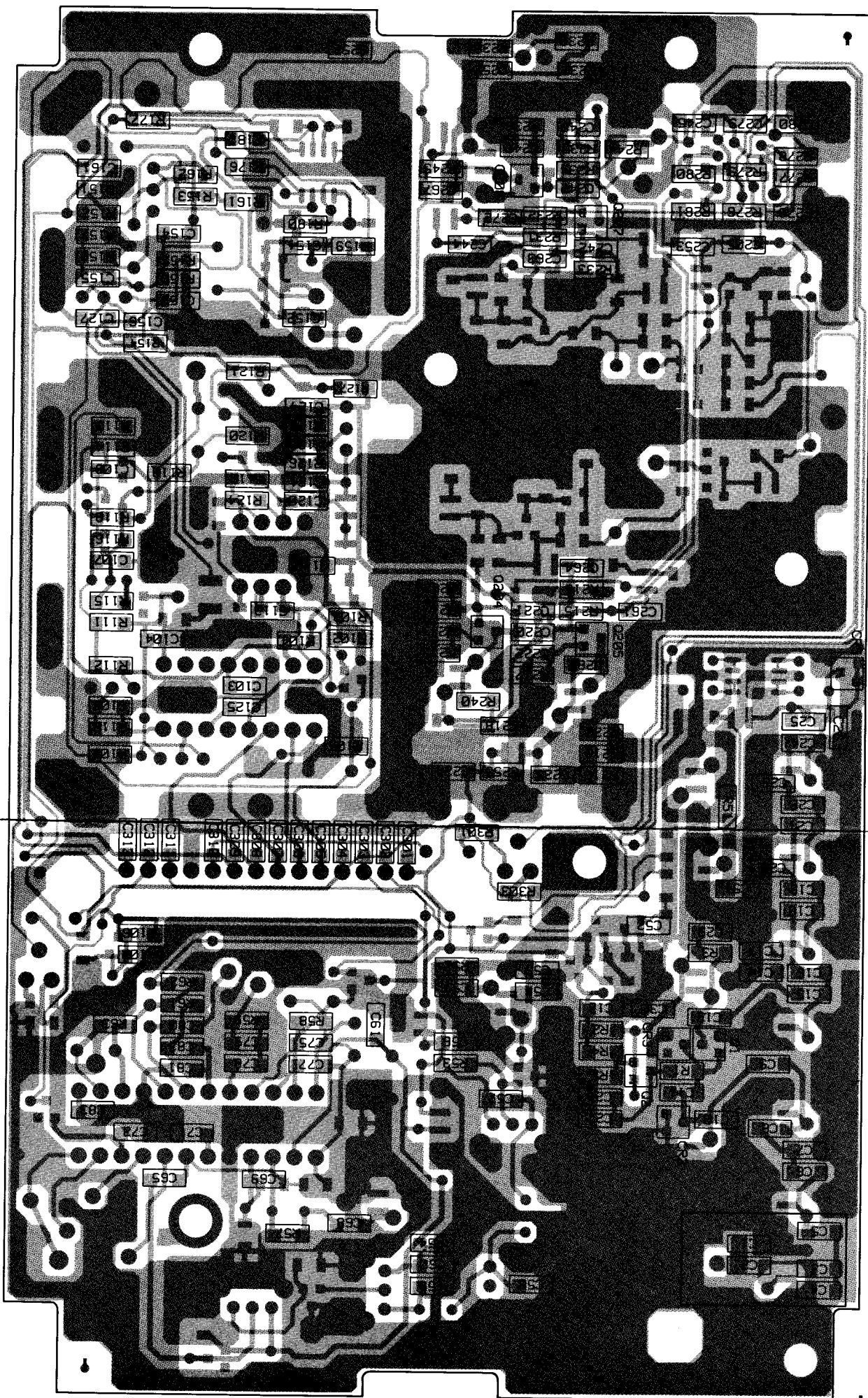

COMPONENT SIDE (Gray)
SOLDER SIDE (Pink)
OVERLAY

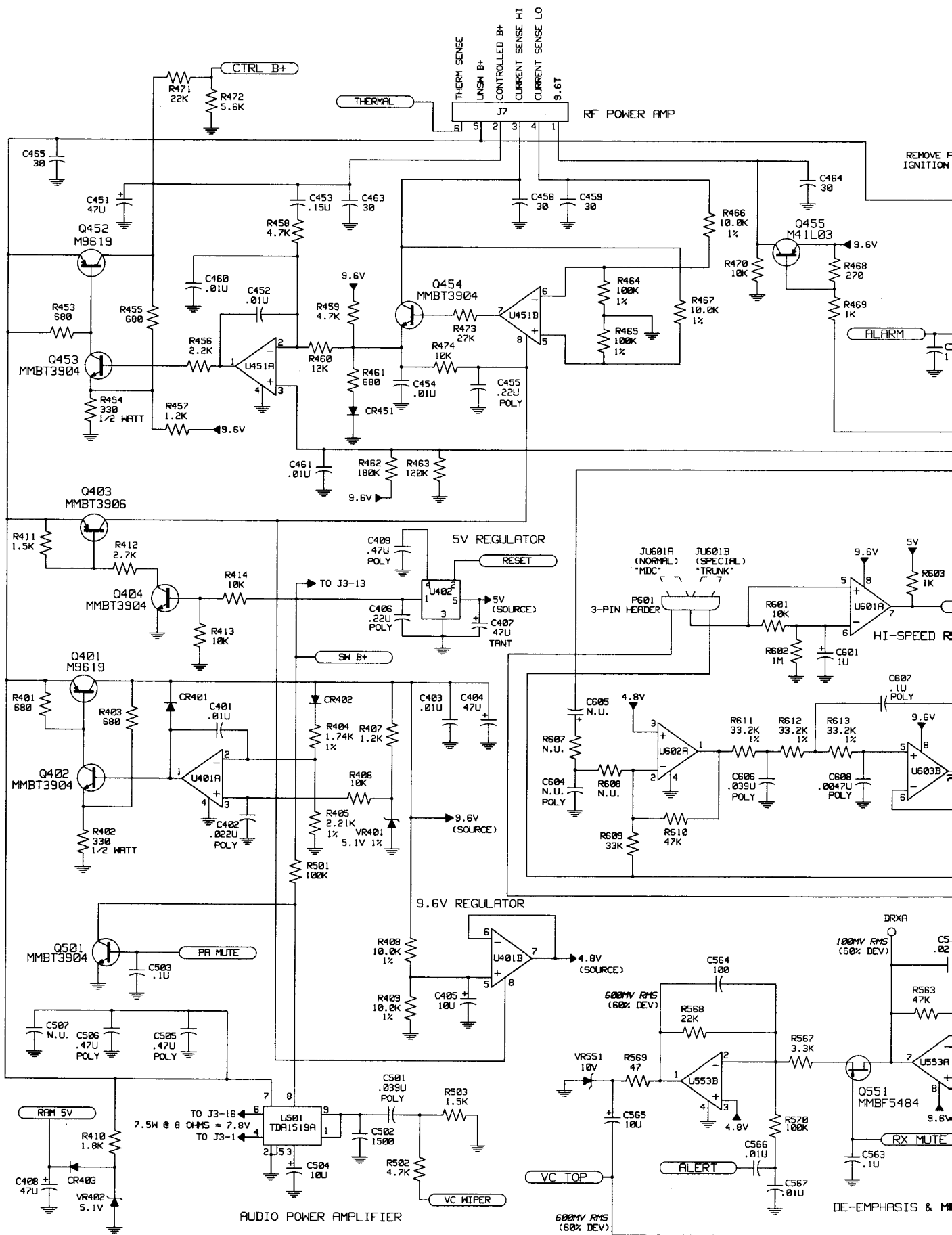

AUDIO POWER AMPLIFIER

ALERT

DE-EMPHASIS & M

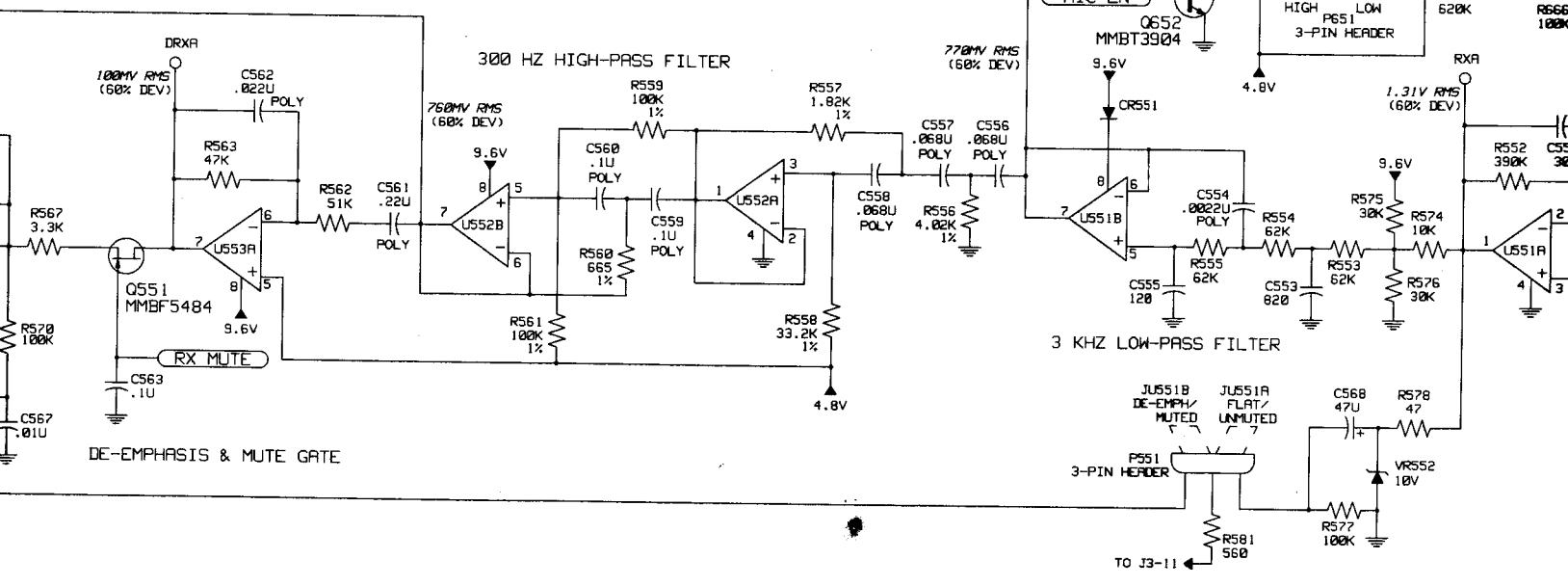
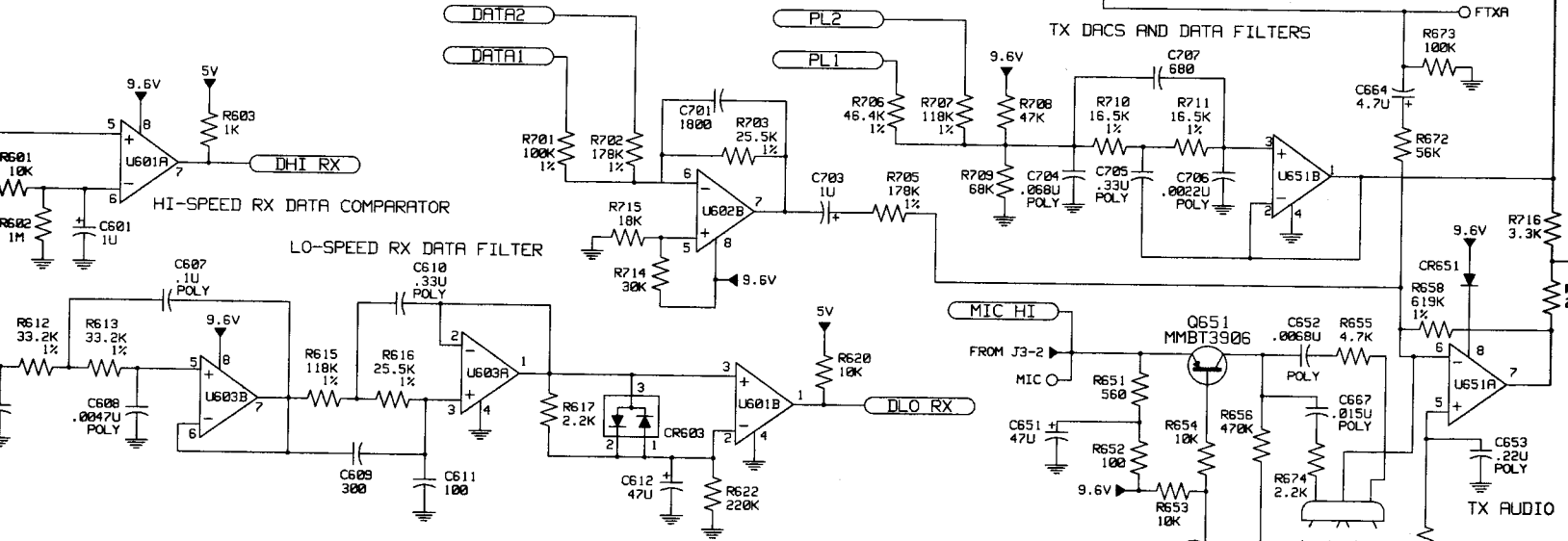
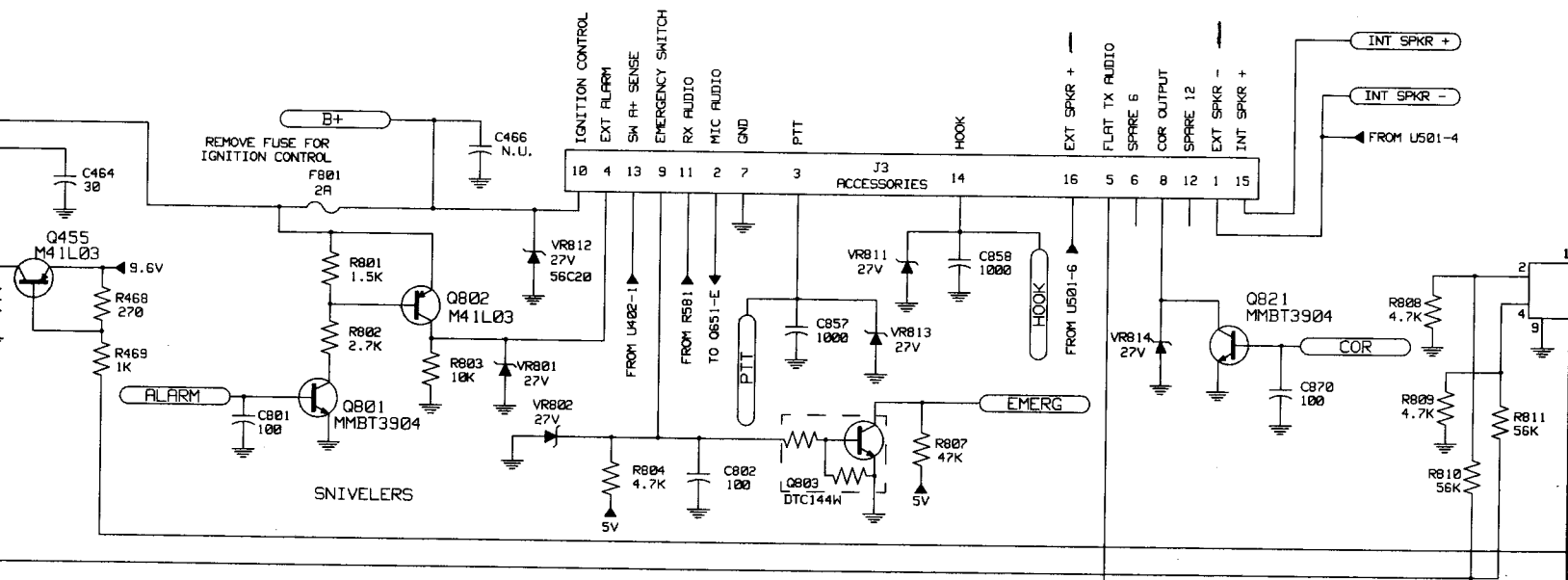

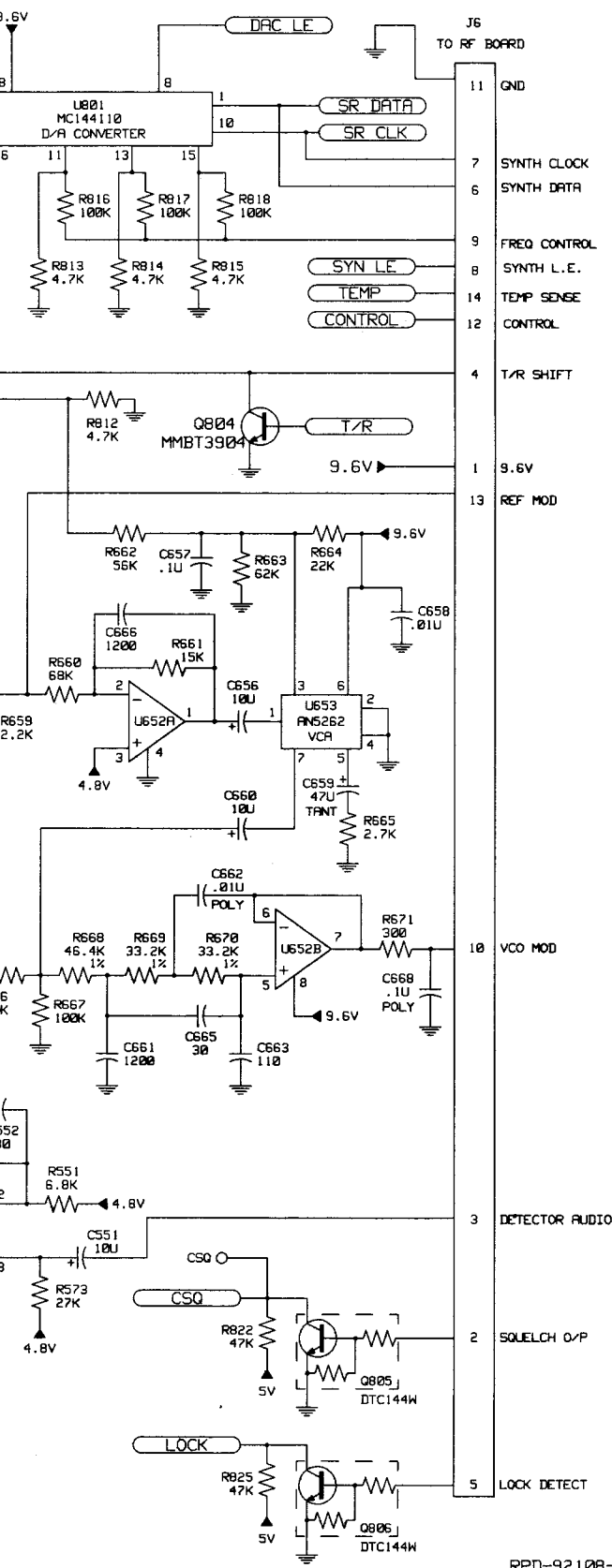

Schematic Diagram for HLN8074
 Logic Board (2-Layer)
 (sheet 1 of 2)

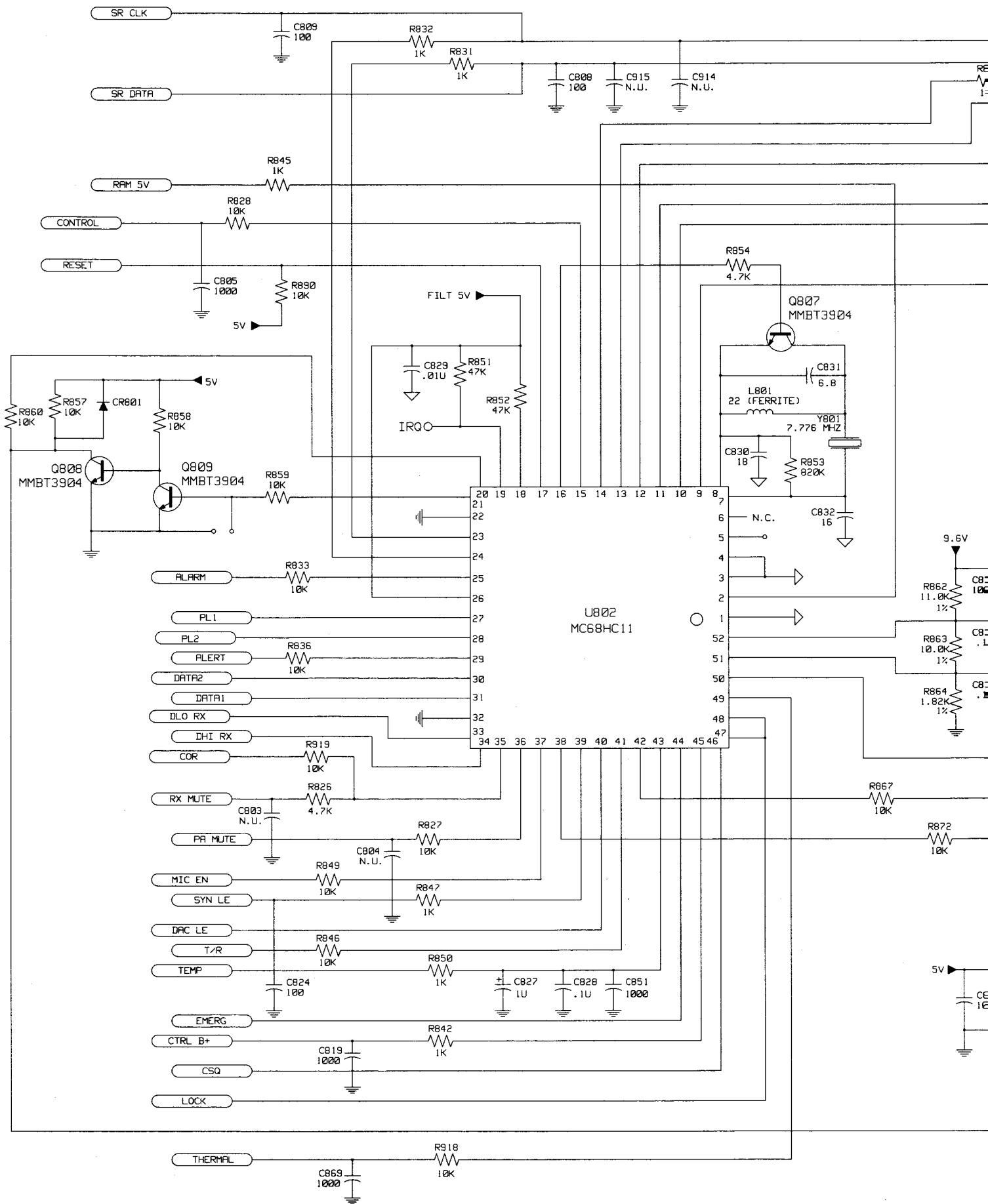

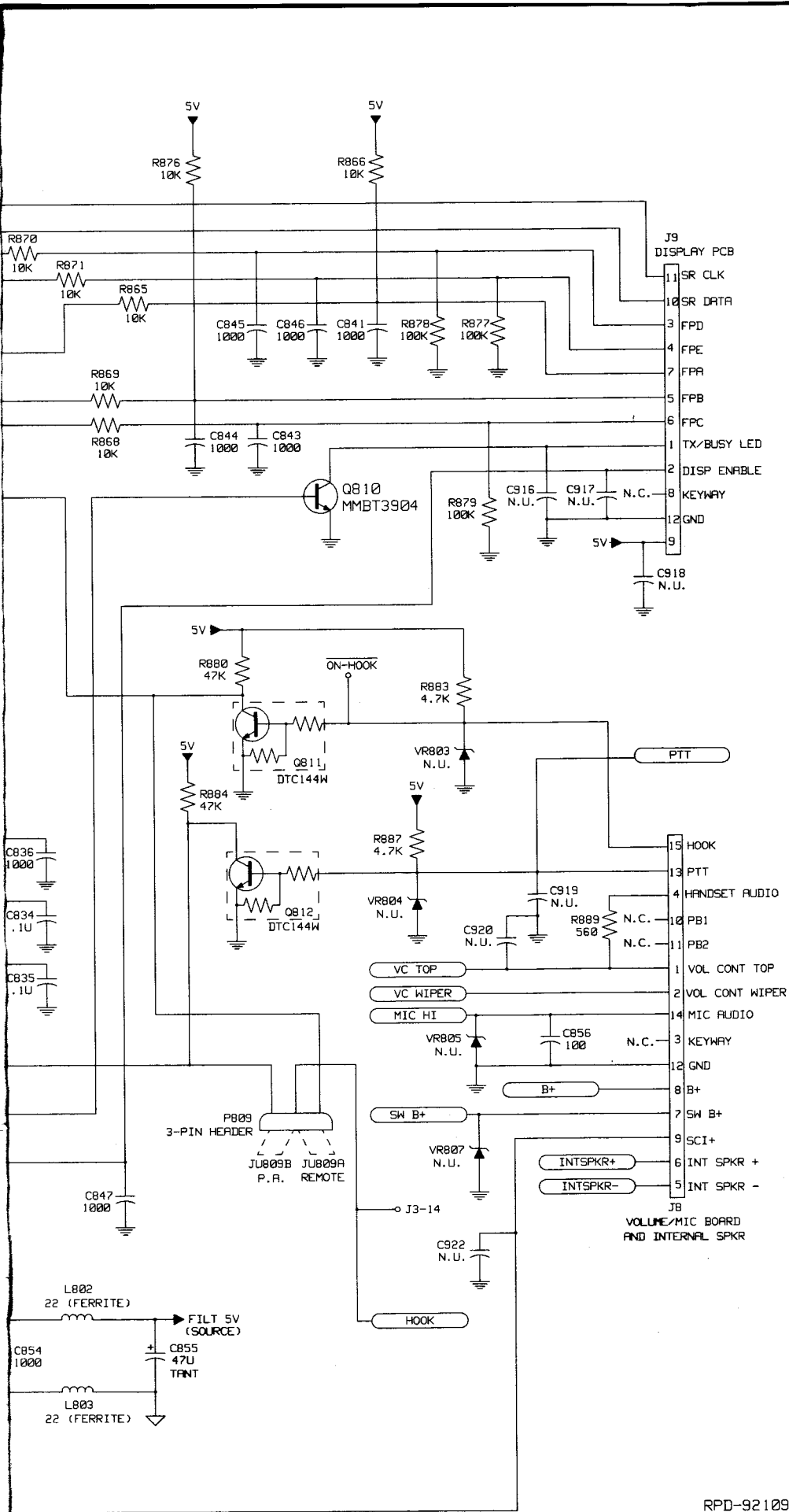

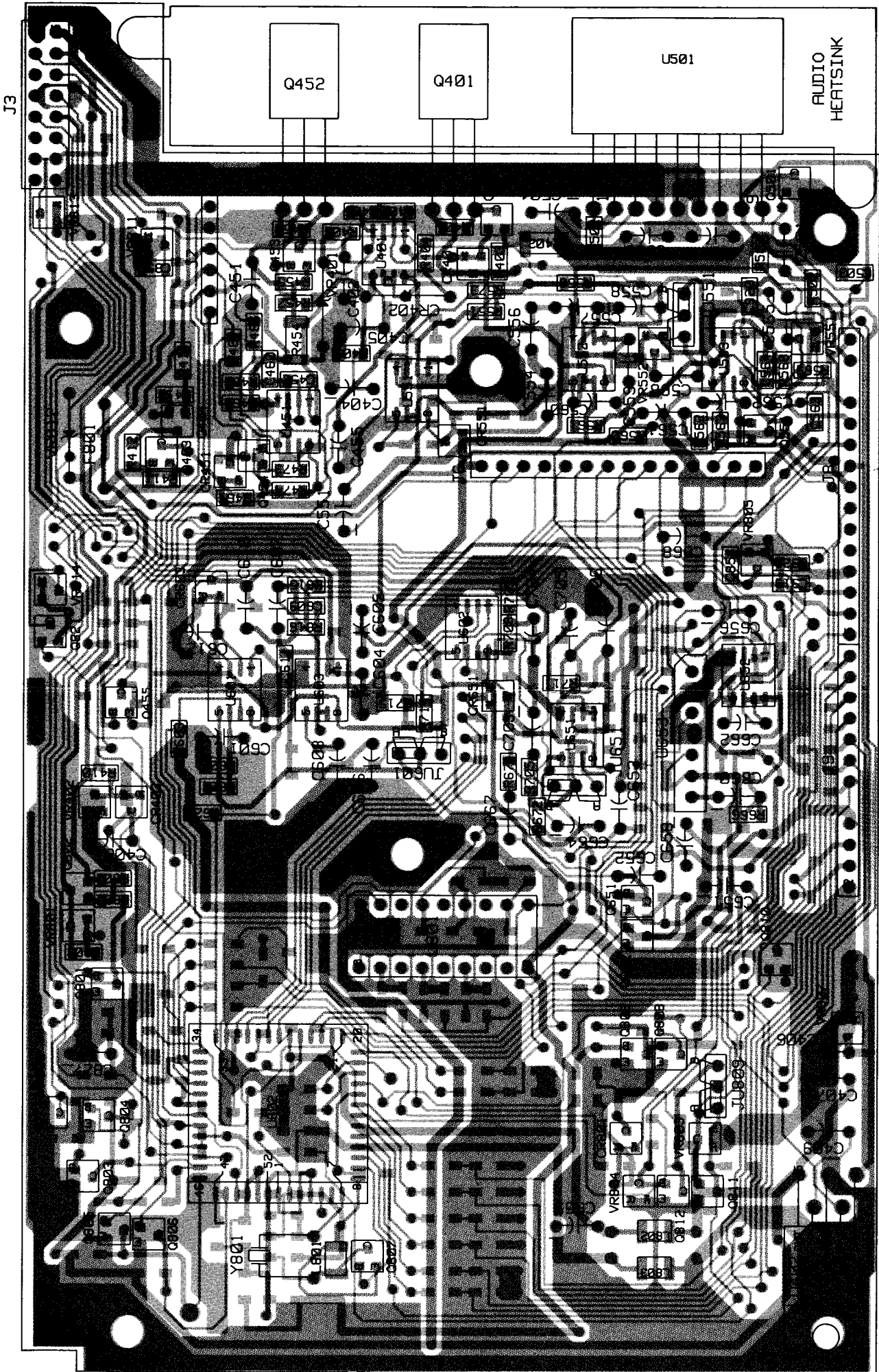

COMPONENT SIDE (Gray)
 SOLDER SIDE (Pink)
 OVERLAY -----

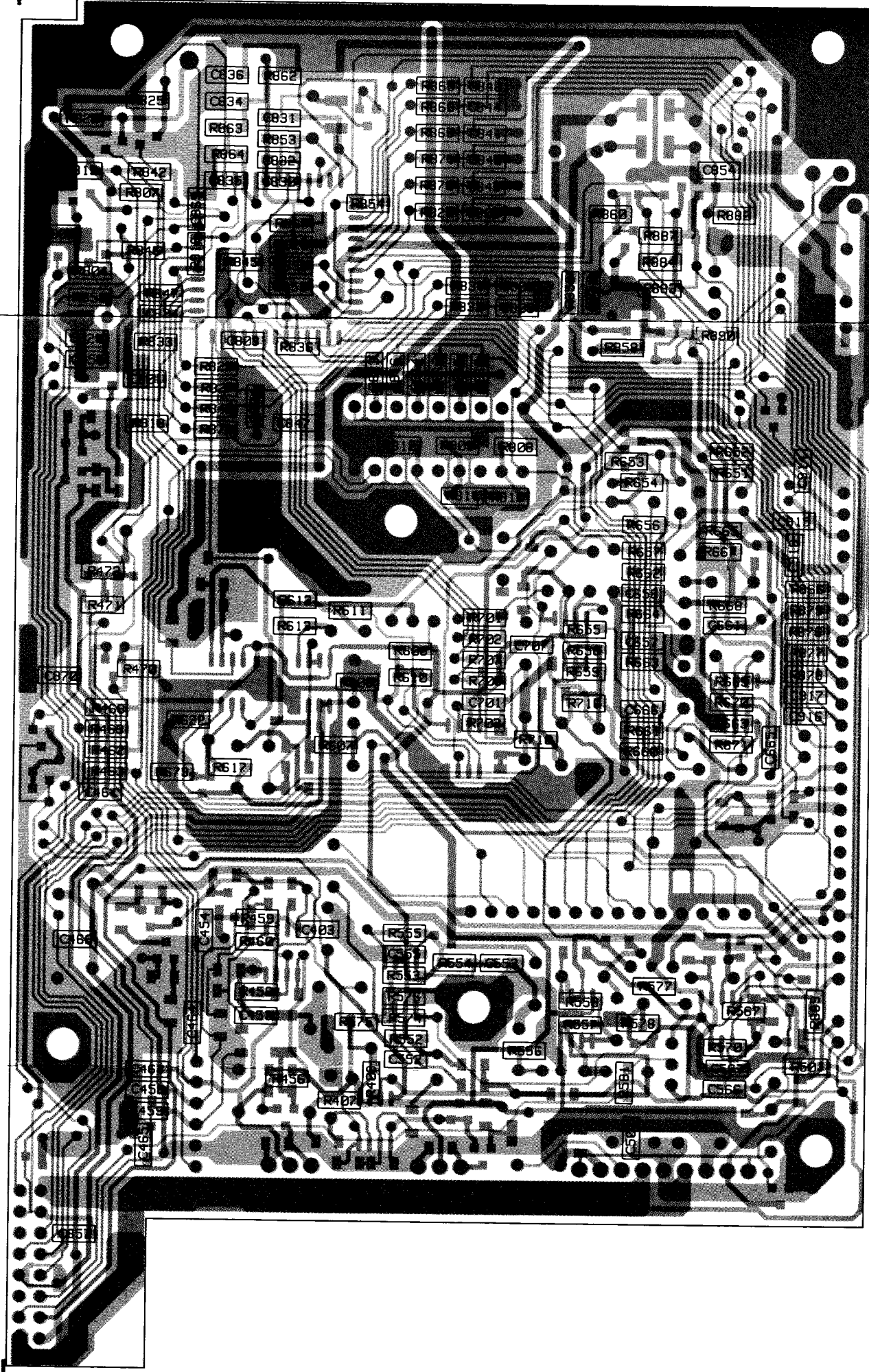

COMPONENT SIDE (Gray)
SOLDER SIDE (Pink)
OVERLAY -----

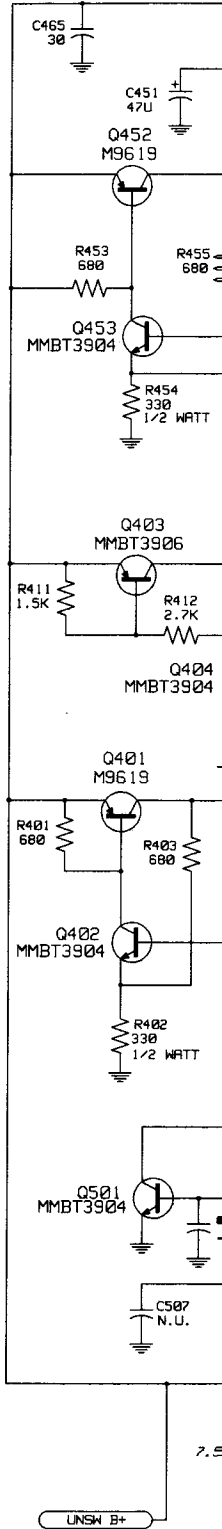

Schematic Diagram for HLN8070A
 PCB Board (4-Layer)

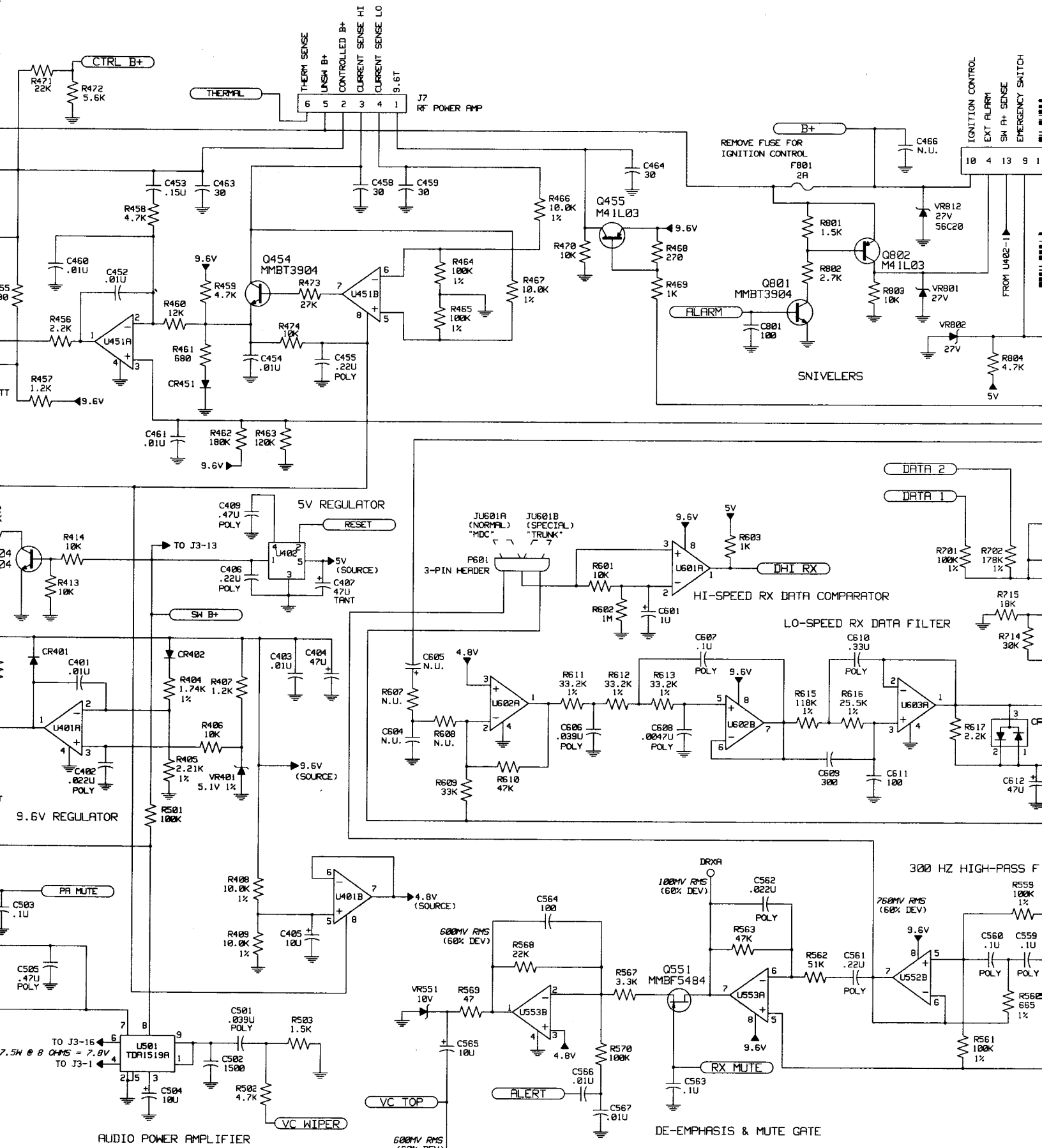

CTRL B+

THERMPL

THERM SENSE
UNSH B+
CONTROLLED B+
CURRENT SENSE HI
CURRENT SENSE LO
9.6V
J7
RF POWER AMP

B+

REMOVE FUSE FOR
IGNITION CONTROL
F801
2A

IGNITION CONTROL
EXT ALARM
SM + SENSE
EMERGENCY SWITCH
10 4 13 9 1

SNIVELERS

5V REGULATOR

RESET

5V (SOURCE)

JU601A (NORMAL) "MDC"
JU601B (SPECIAL) "TRUNK"

3-PIN HEADER

HI-SPEED RX DATA COMPARATOR

LO-SPEED RX DATA FILTER

9.6V REGULATOR

PA MUTE

4.8V (SOURCE)

600mV RMS (60% DEV)

100mV RMS (60% DEV)

300 HZ HIGH-PASS F

750mV RMS (60% DEV)

600mV RMS (60% DEV)

DE-EMPHASIS & MUTE GATE

AUDIO POWER AMPLIFIER

VC WIPER

ALERT

RX MUTE

7.5M @ 8 OHMS = 7.8V
TO J3-16
TO J3-1

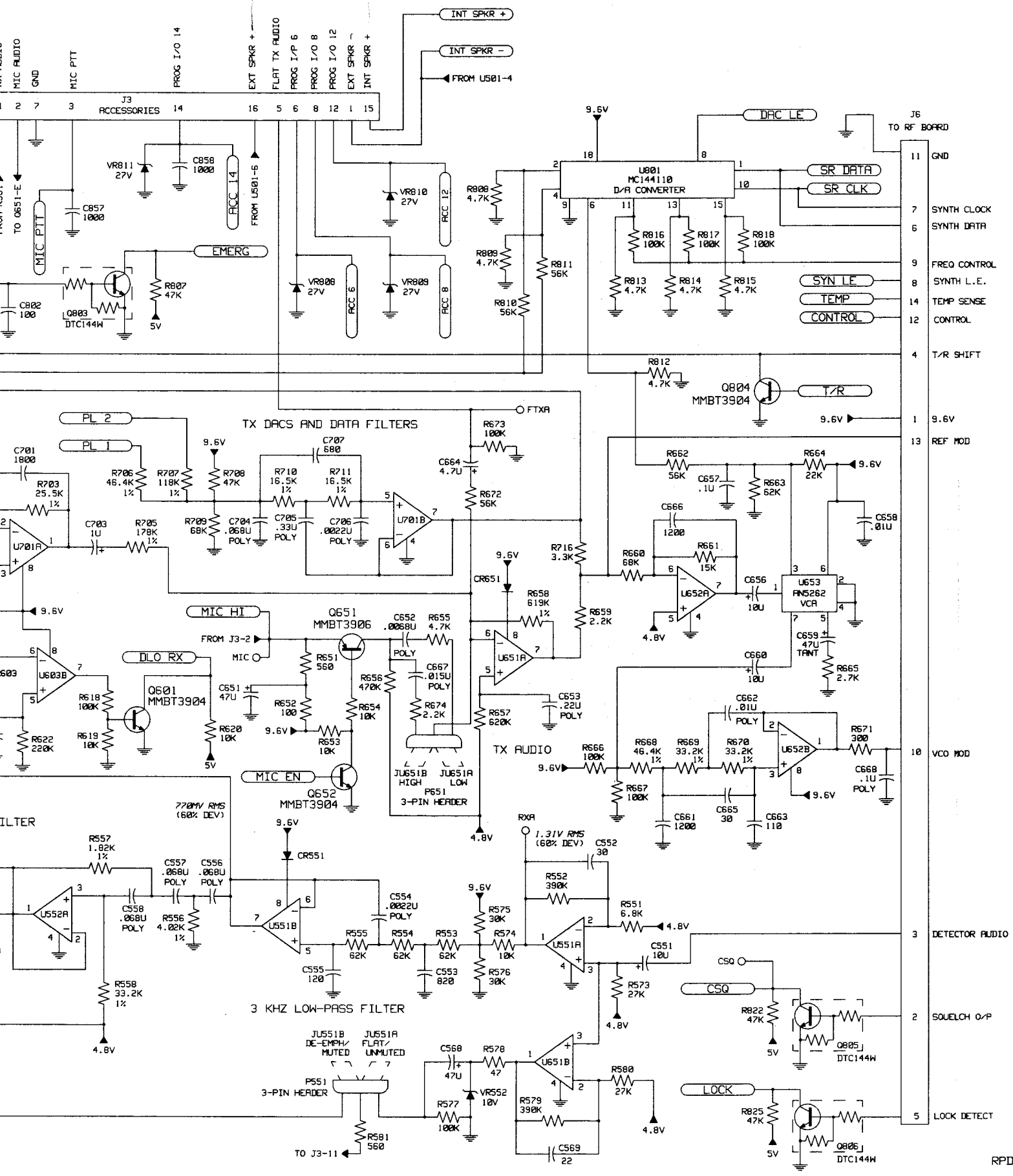

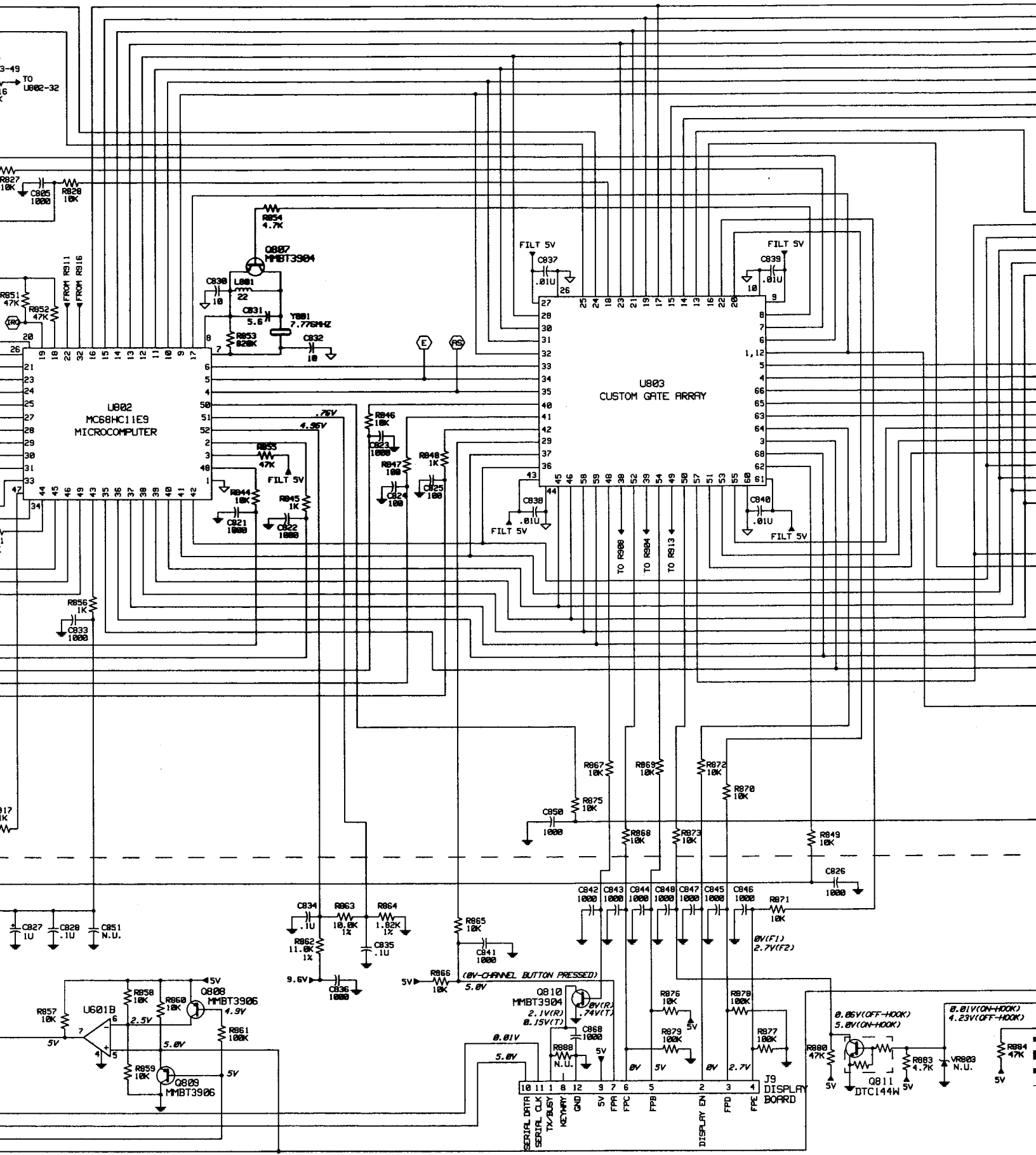

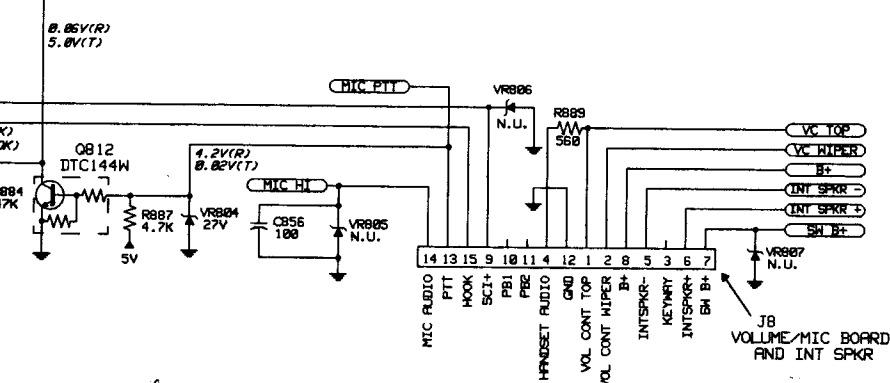
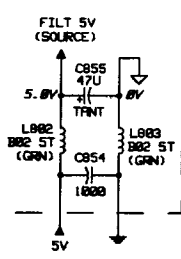
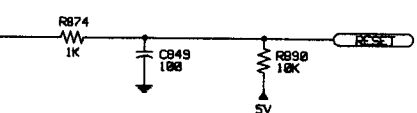
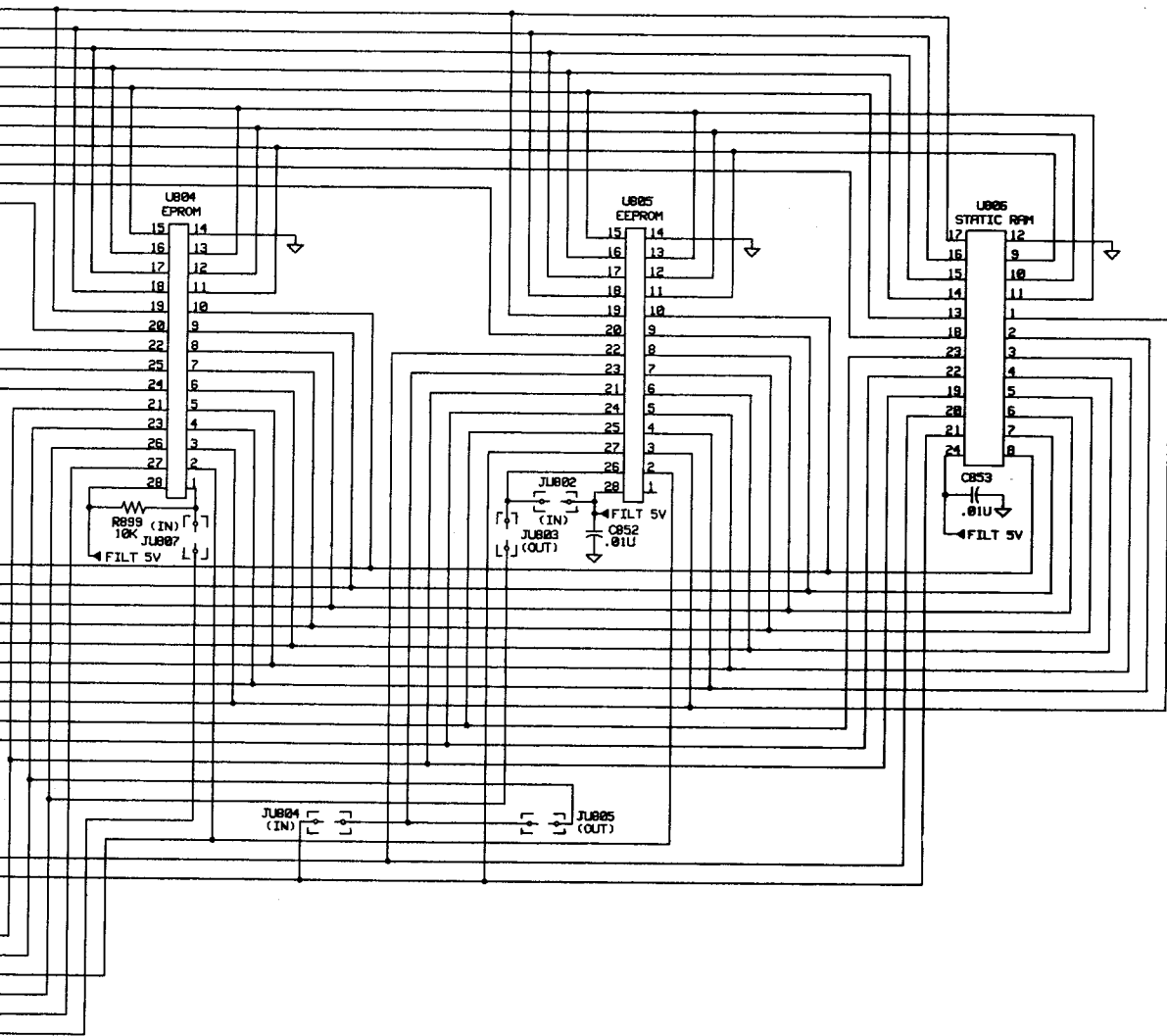

Schematic Diagram for 4LN80204 Logic Board (4-Layer)

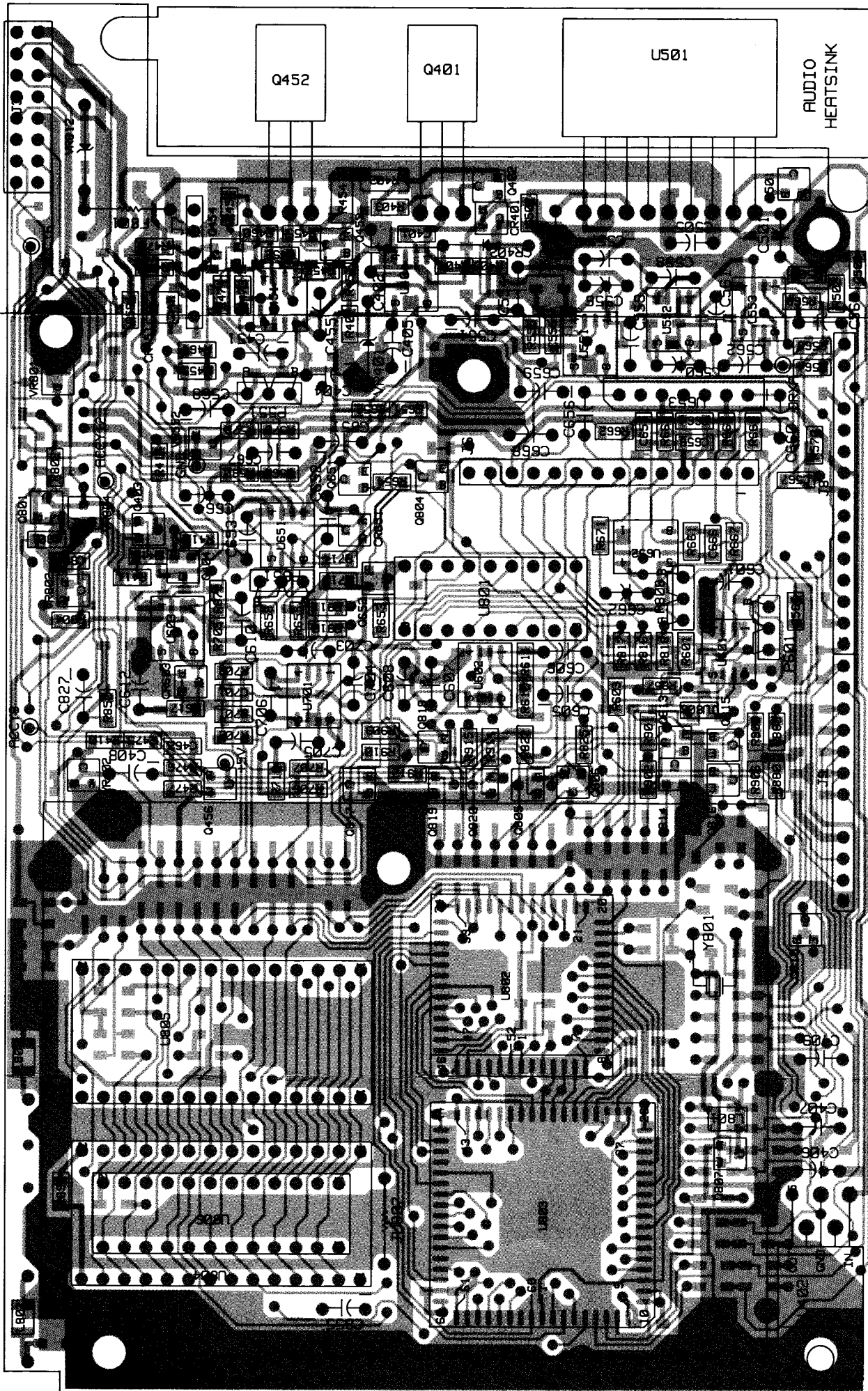

Q452

Q401

U501

AUDIO
HEATSINK

HLN 8070A

COMPONENT SIDE

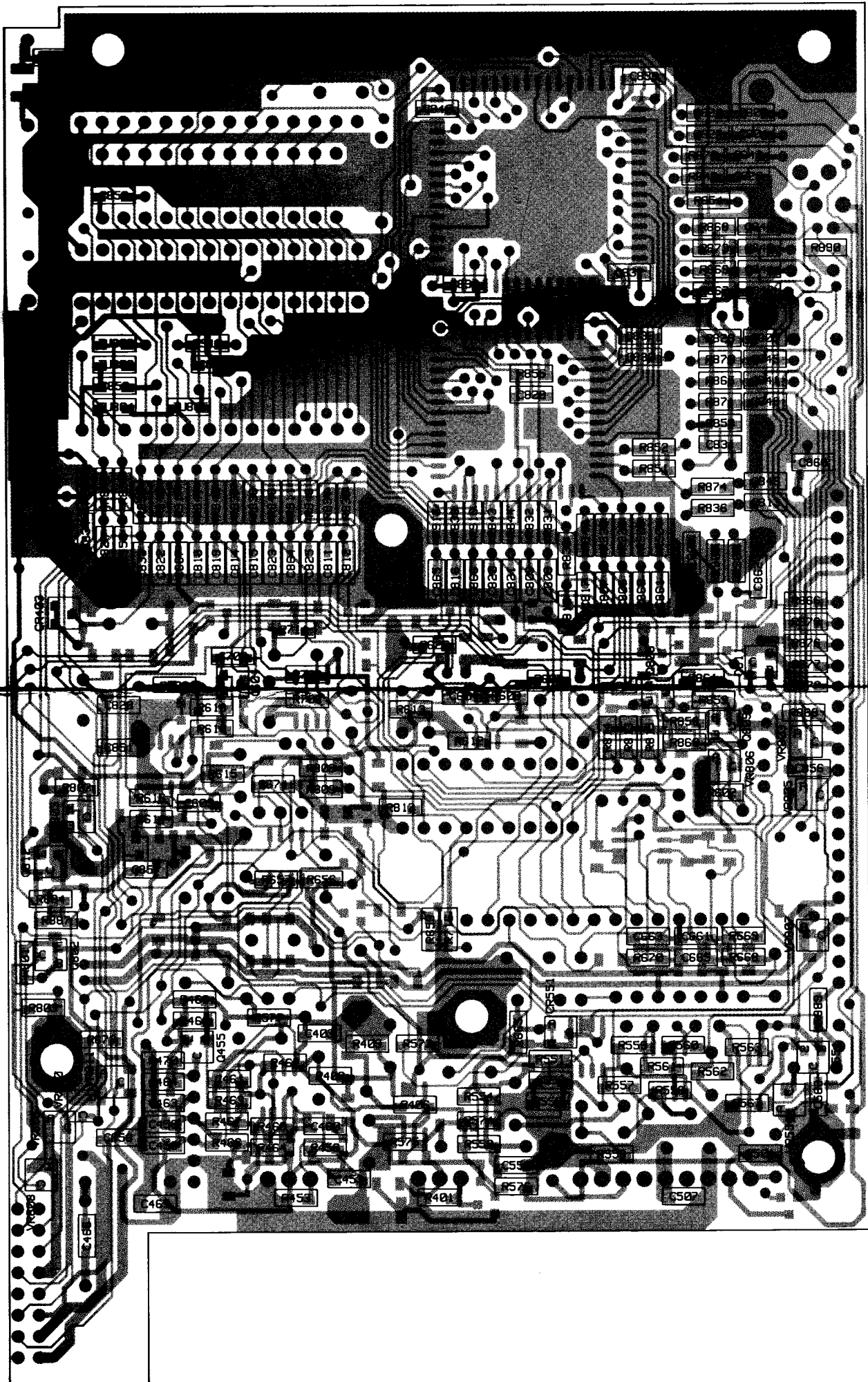

SOLDER SIDE

COMPONENT SIDE

P4
(MATES WITH J4 ON
RF BRD)

P5
(MATES WITH J5 ON
RF BRD)

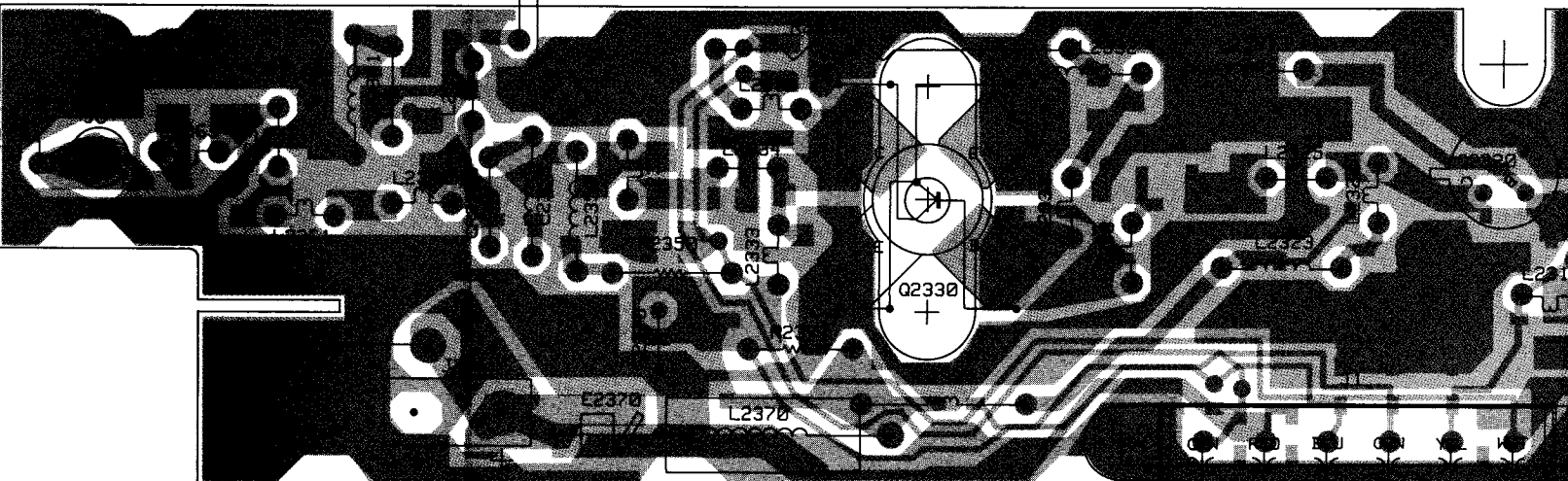

* INCLUDES INTERGAL
FEEDTHRU CAPACITOR

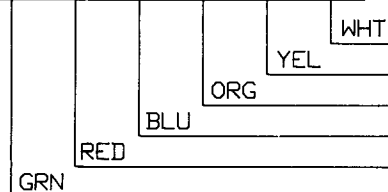

COMPONENT SIDE (Gray)
SOLDER SIDE (Pink)
OVERLAY -----

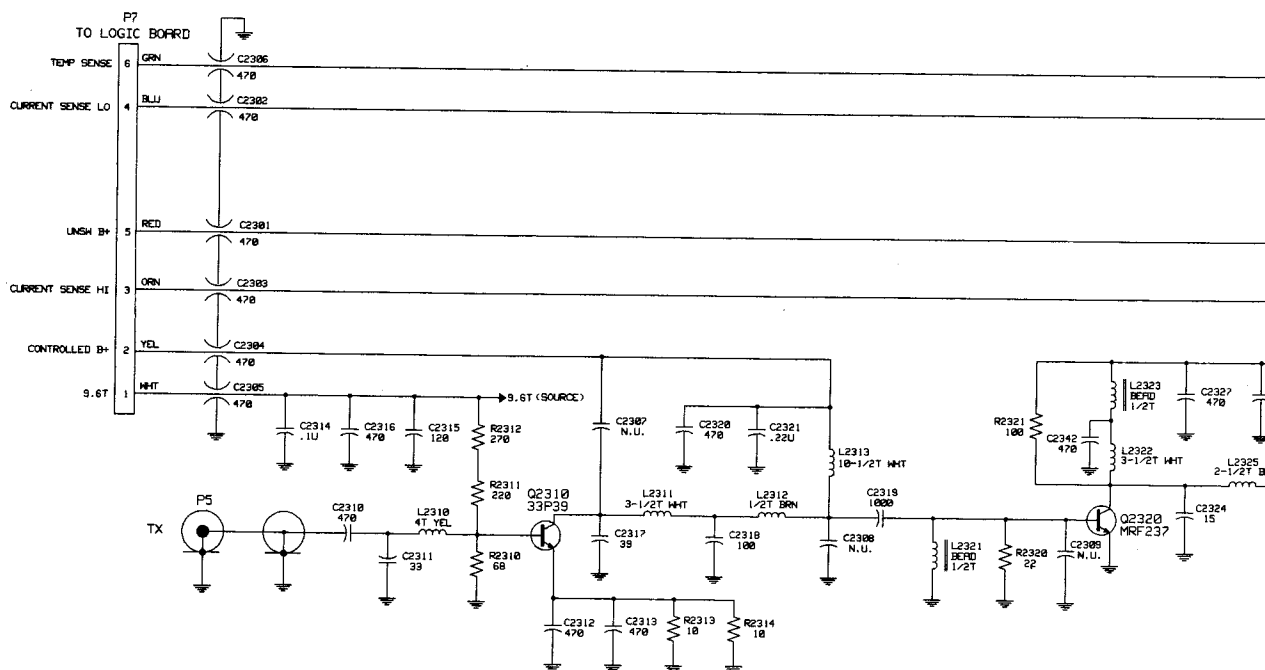

SLIDER SIDE

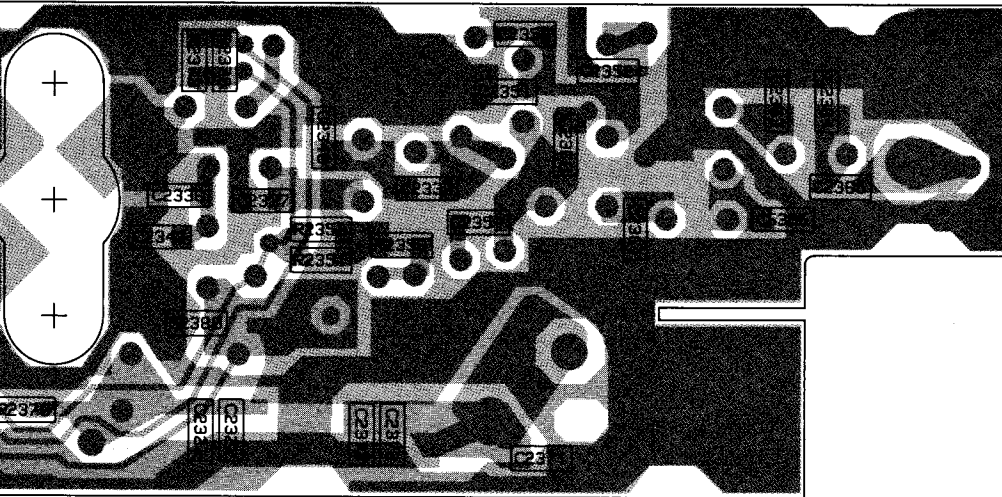

FRONT SIDE (Gray)

SLIDER SIDE (Pink)

OVERLAY -----

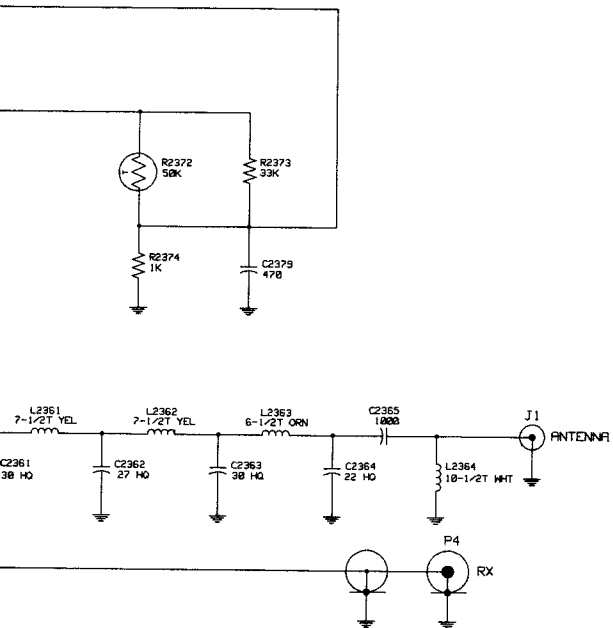

Circuit Board Details

HLD 3502A
10-25 Watt VHF Power Amplifier

SOLDER SIDE

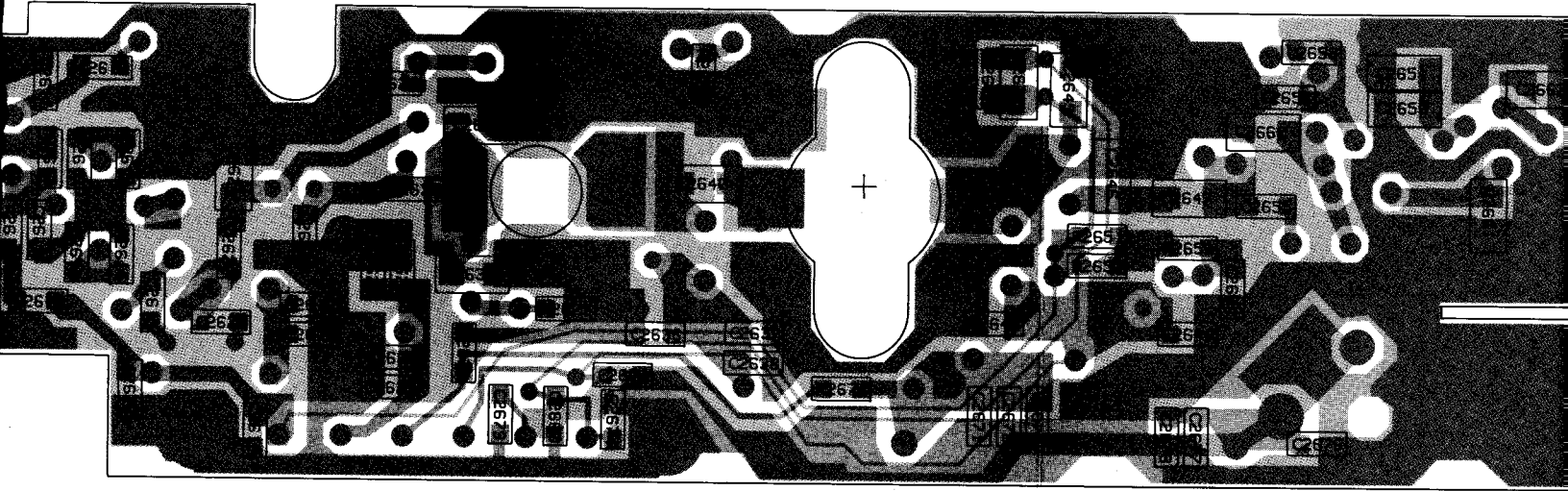

COMPONENT SIDE (Gray)

SOLDER SIDE (Pink)

OVERLAY -----

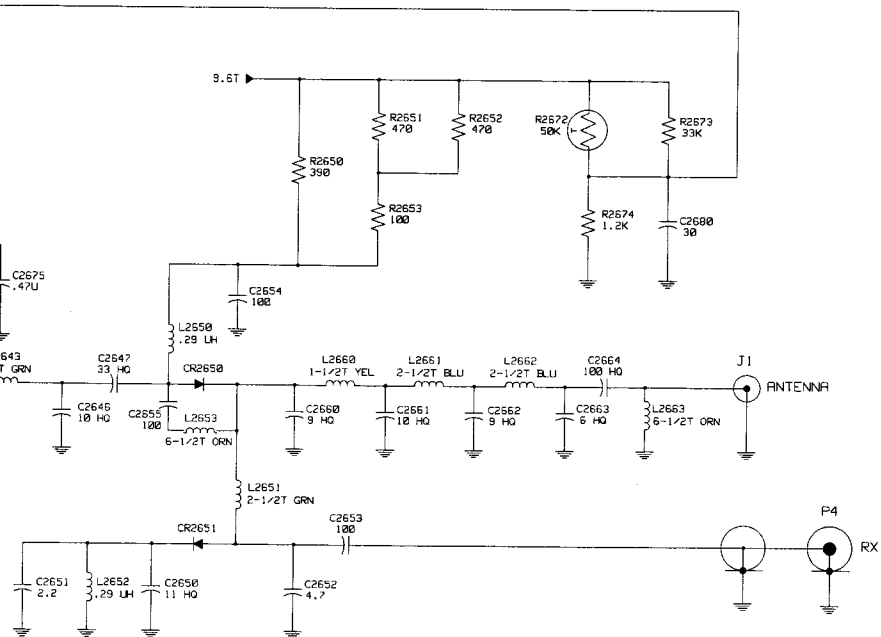

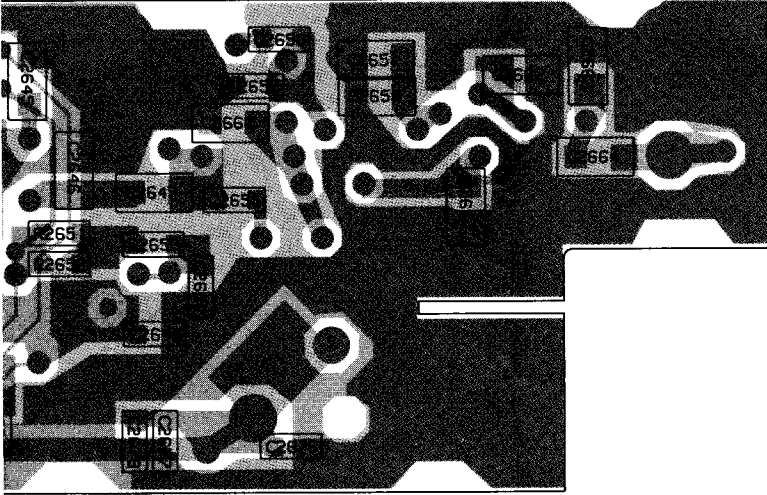

ay)
ink)

COMPONENT SIDE

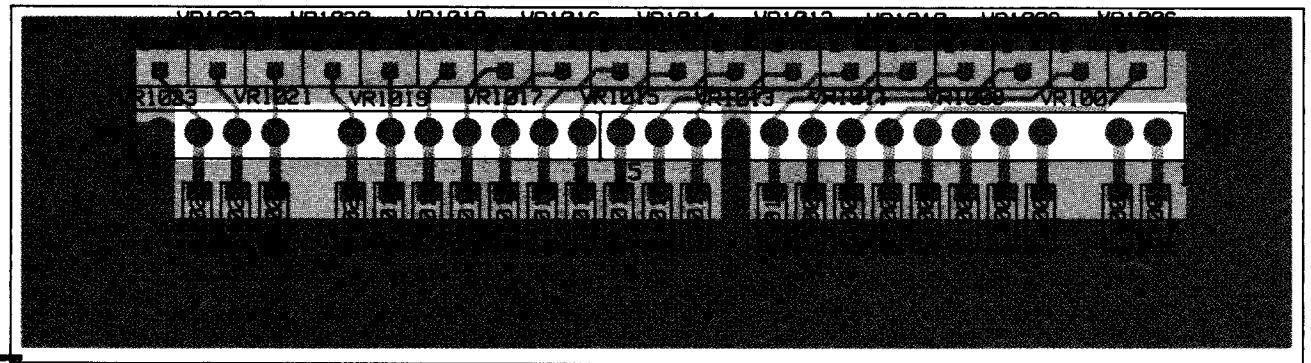

COMPONENT SIDE (Gray)

SOLDER SIDE (Pink)

OVERLAY -----

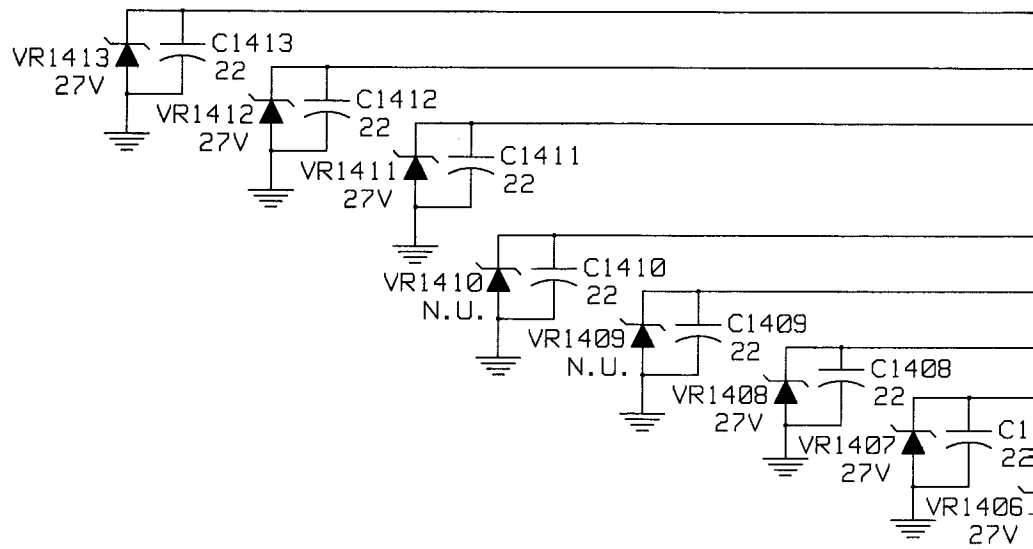
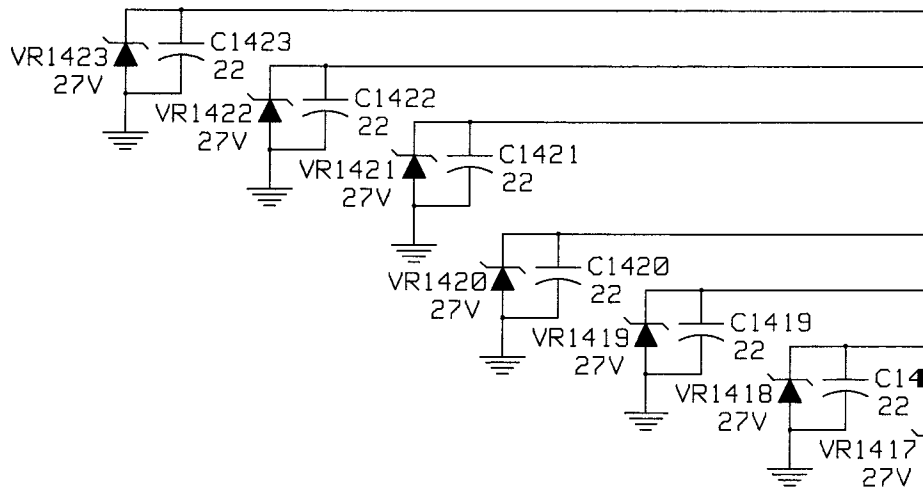

DISPLAY PCB
(FITS OVER PINS OF J9 ON LOGIC BOARD)

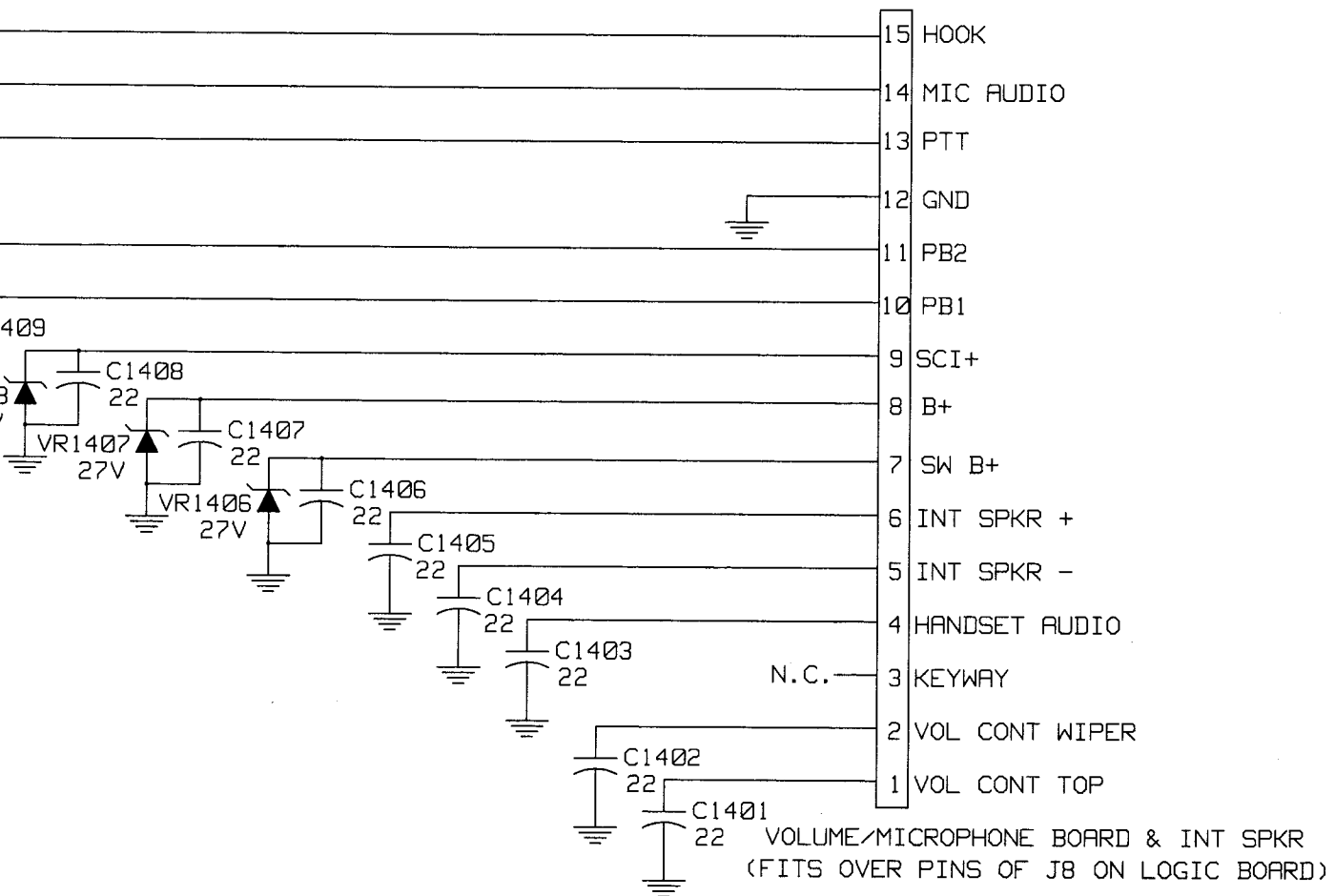
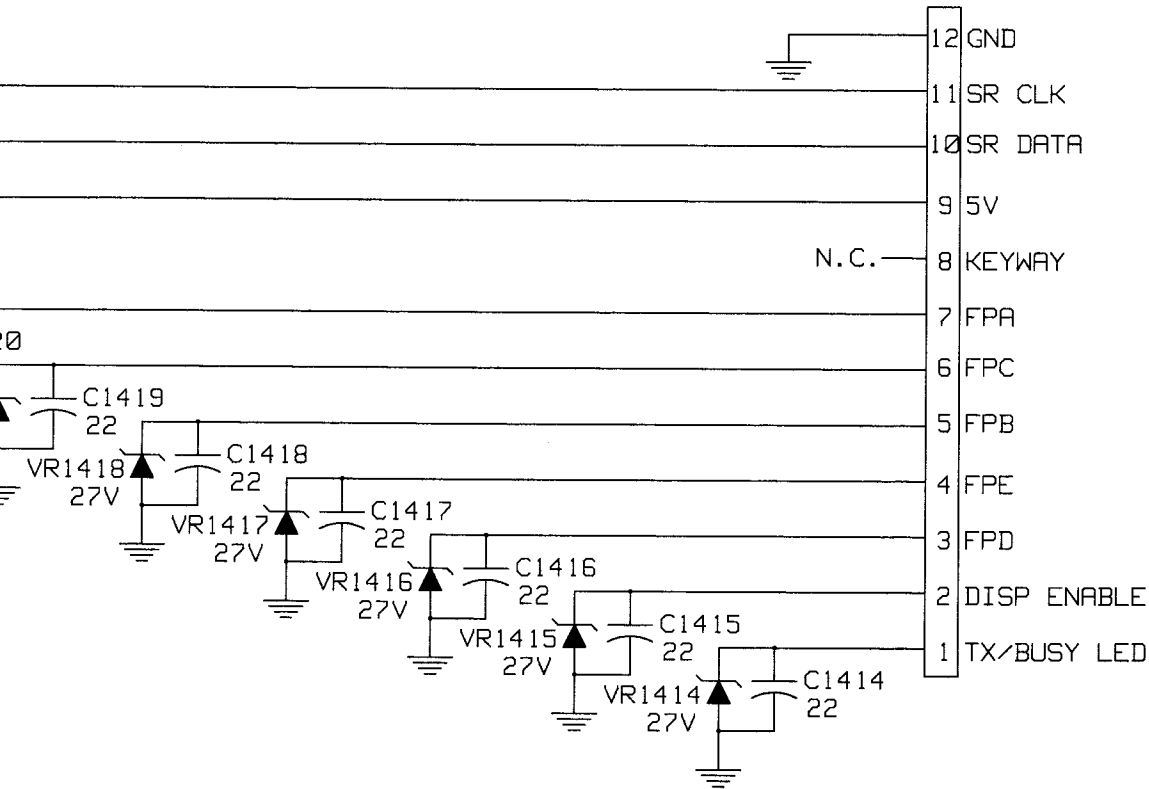

01-80704Y83 Front Panel Filter Board

REFERENCE NUMBER	MOTOROLA PART NO.	DESCRIPTION
Capacitor, chip, 5%, 50V unless otherwise indicated.		
C1401	21-13740B33	22 pF
C1402	21-13740B33	22 pF
C1403	21-13740B33	22 pF
C1404	21-13740B33	22 pF
C1405	21-13740B33	22 pF
C1406	21-13740B33	22 pF
C1407	21-13740B33	22 pF
C1408	21-13740B33	22 pF
C1409	21-13740B33	22 pF
C1410	21-13740B33	22 pF
C1411	21-13740B33	22 pF
C1412	21-13740B33	22 pF
C1413	21-13740B33	22 pF
C1414	21-13740B33	22 pF
C1415	21-13740B33	22 pF
C1416	21-13740B33	22 pF
C1417	21-13740B33	22 pF
C1418	21-13740B33	22 pF
C1419	21-13740B33	22 pF
C1420	21-13740B33	22 pF
C1421	21-13740B33	22 pF
C1422	21-13740B33	22 pF
C1423	21-13740B33	22 pF

Voltage regulators (see note)

VR1406	48-80948V01	zener diode 27V SOT
VR1407	48-80948V01	zener diode 27V SOT
VR1408	48-80948V01	zener diode 27V SOT
VR1409		not used
VR1410		not used
VR1411	48-80948V01	zener diode 27V SOT
VR1412	48-80948V01	zener diode 27V SOT
VR1413	48-80948V01	zener diode 27V SOT
VR1414	48-80948V01	zener diode 27V SOT
VR1415	48-80948V01	zener diode 27V SOT
VR1416	48-80948V01	zener diode 27V SOT
VR1417	48-80948V01	zener diode 27V SOT
VR1418	48-80948V01	zener diode 27V SOT
VR1419	48-80948V01	zener diode 27V SOT
VR1420	48-80948V01	zener diode 27V SOT
VR1421	48-80948V01	zener diode 27V SOT
VR1422	48-80948V01	zener diode 27V SOT
VR1423	48-80948V01	zener diode 27V SOT

Note: For optimum performance, diodes, transistors, and integrated circuits must be ordered by Motorola part numbers.

3/12/92

PL-921014-O

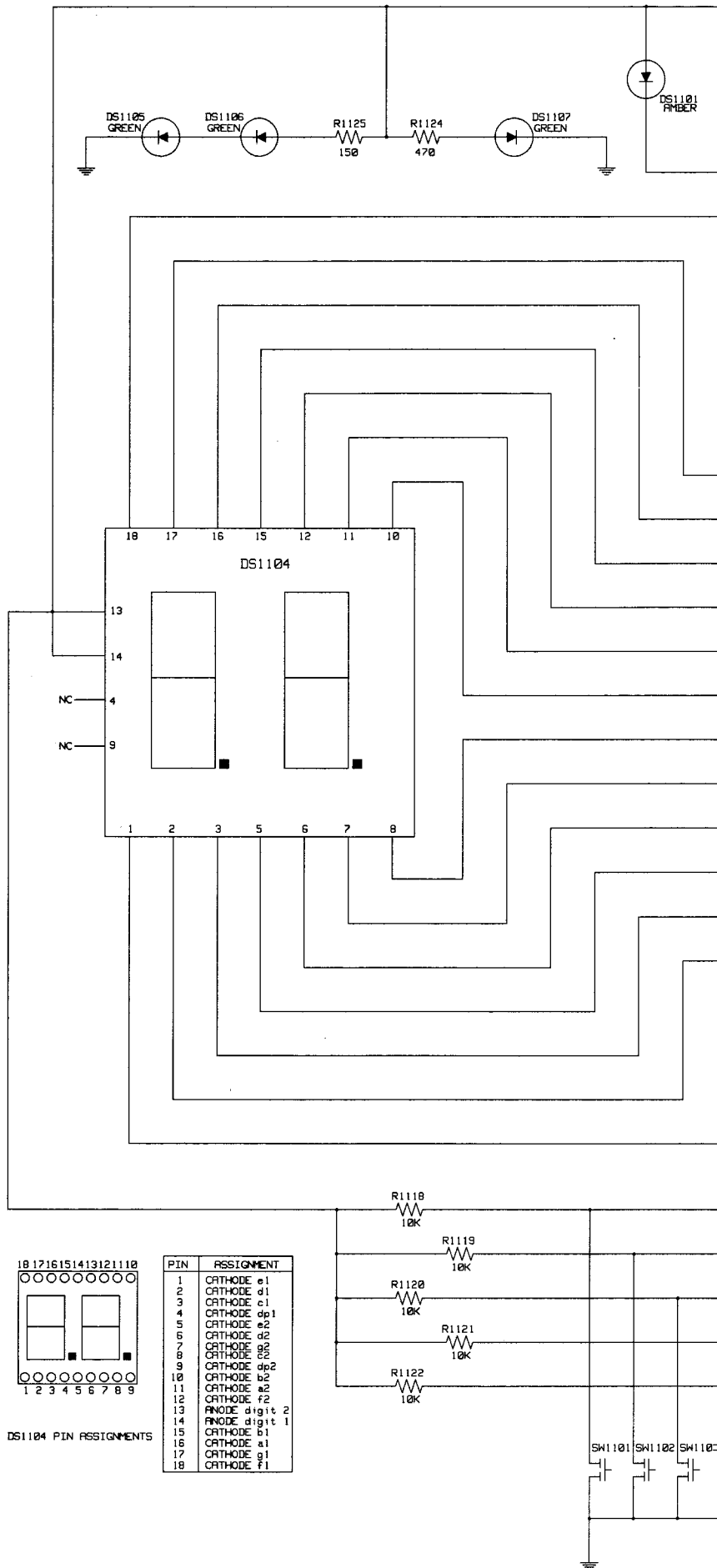

Circuit Board Detail, Schematic and Parts List for HLN8075A Display Board

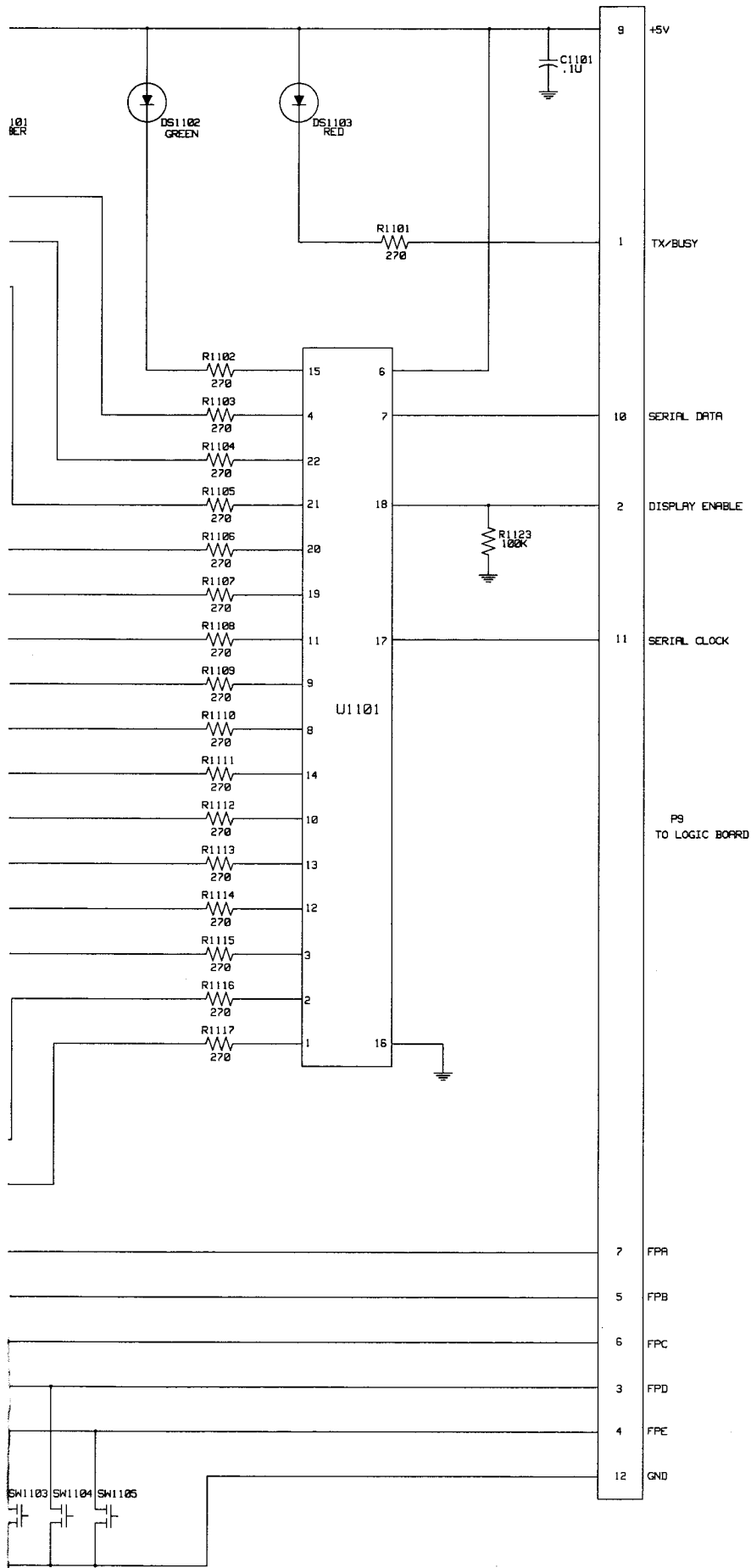

+5V

TX/BUSY

SERIAL DATA

DISPLAY ENABLE

SERIAL CLOCK

P9
TO LOGIC BOARD

FPA

FPB

FPC

FPD

FPE

GND

HLN8075A Display Board

REFERENCE NUMBER	MOTOROLA PART NO.	DESCRIPTION
------------------	-------------------	-------------

Capacitor, chip, 5%, 50V unless otherwise indicated.

C1101 21-13741B69 .1 uF

Displays and Indicators

DS1101	48-80051M03	diode LED amber
DS1102	48-80051M02	diode LED green
DS1103	48-80051M01	diode LED red
DS1104	48-80055M01	dual 7 segment LED
DS1105	48-83636N04	diode LED green
DS1106	48-83636N04	diode LED green
DS1107	48-83636N04	diode LED green

Resistors, chip, 5%, 1/10 watt, unless otherwise indicated.

R1101	06-11077A60	270
R1102	06-11077A60	270
R1103	06-11077A60	270
R1104	06-11077A60	270
R1105	06-11077A60	270
R1106	06-11077A60	270
R1107	06-11077A60	270
R1108	06-11077A60	270
R1109	06-11077A60	270
R1110	06-11077A60	270
R1111	06-11077A60	270
R1112	06-11077A60	270
R1113	06-11077A60	270
R1114	06-11077A60	270
R1115	06-11077A60	270
R1116	06-11077A60	270
R1117	06-11077A60	270
R1118	06-11077A98	10k
R1119	06-11077A98	10k
R1120	06-11077A98	10k
R1121	06-11077A98	10k
R1122	06-11077A98	10k
R1123	06-11077B23	100k
R1124	06-11077A66	470
R1125	06-11077A54	150

Integrated circuits and modules (see note)

U1101 51-84437N25 driver, serial to parallel

Non-referenced items

01-80747T11	cable assembly (includes P9)
42-80053N01	ground strap
43-80278L01	spacer, LED display
43-80280L01	spacer, LED

Note: For optimum performance, diodes, transistors, and integrated circuits must be ordered by Motorola part numbers.

3/12/92

PL-921013-O

COMPONENT SIDE

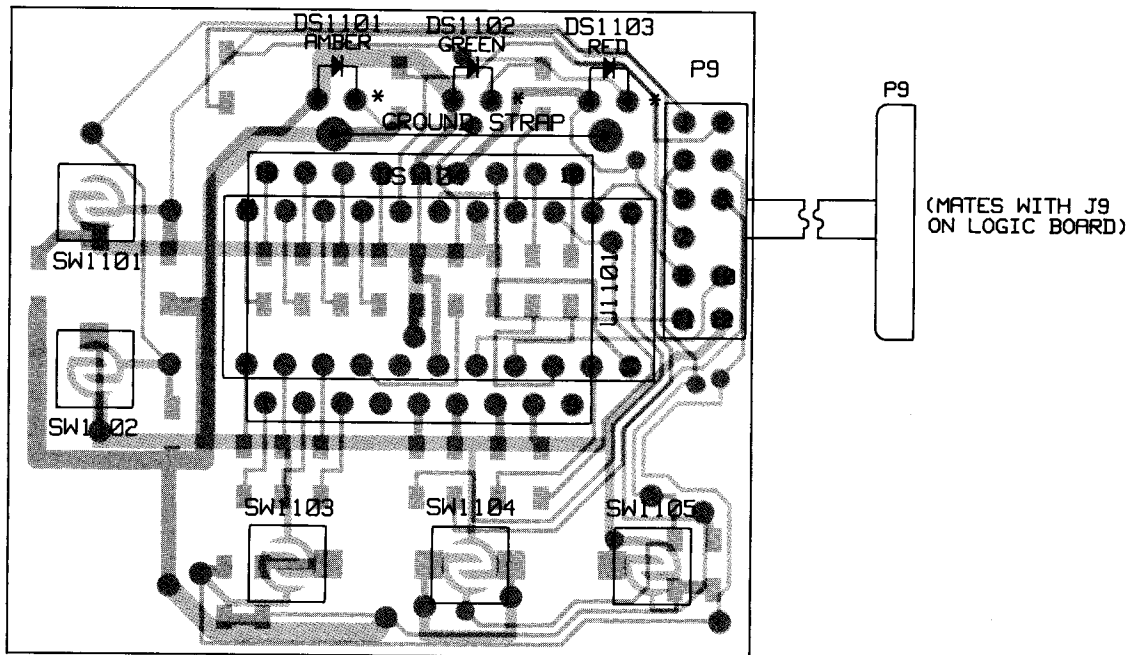

COMPONENT SIDE (Gray)

SOLDER SIDE (Pink)

OVERLAY -----

ES WITH J9
OGIC BOARD)

SOLDER SIDE

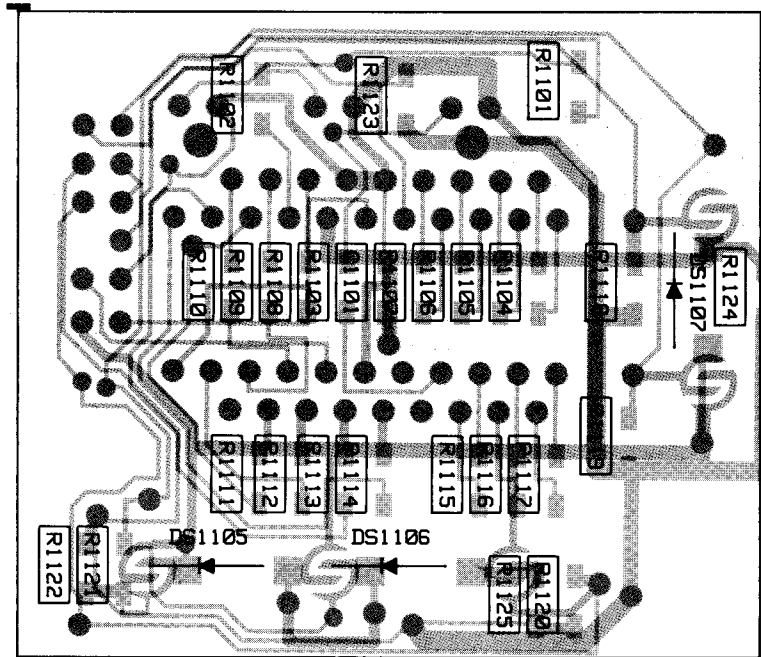

COMPONENT SIDE (Gray)

SOLDER SIDE (Pink)

OVERLAY -----

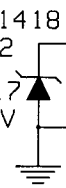

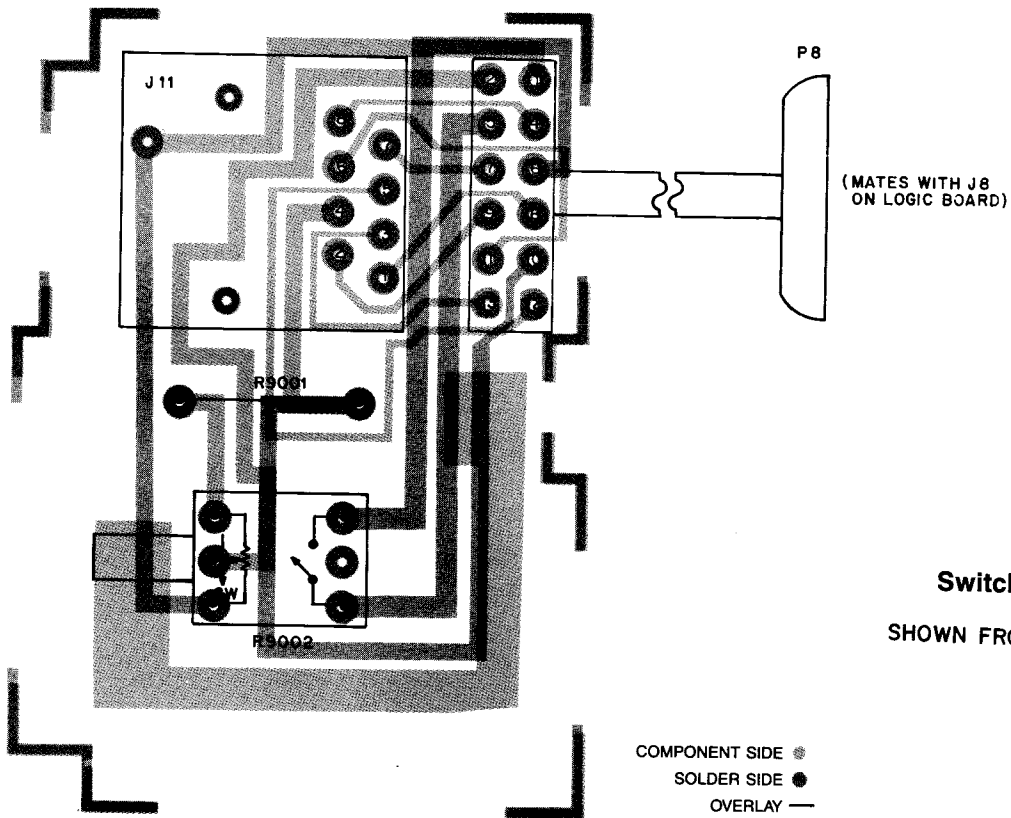

(MATES WITH J8
ON LOGIC BOARD)

Switchboard
SHOWN FROM COMPONENT SIDE

COMPONENT SIDE ●
SOLDER SIDE ●
OVERLAY —

J11
MICROPHONE CONNECTOR
(VIEW FROM FRONT OF RADIO)

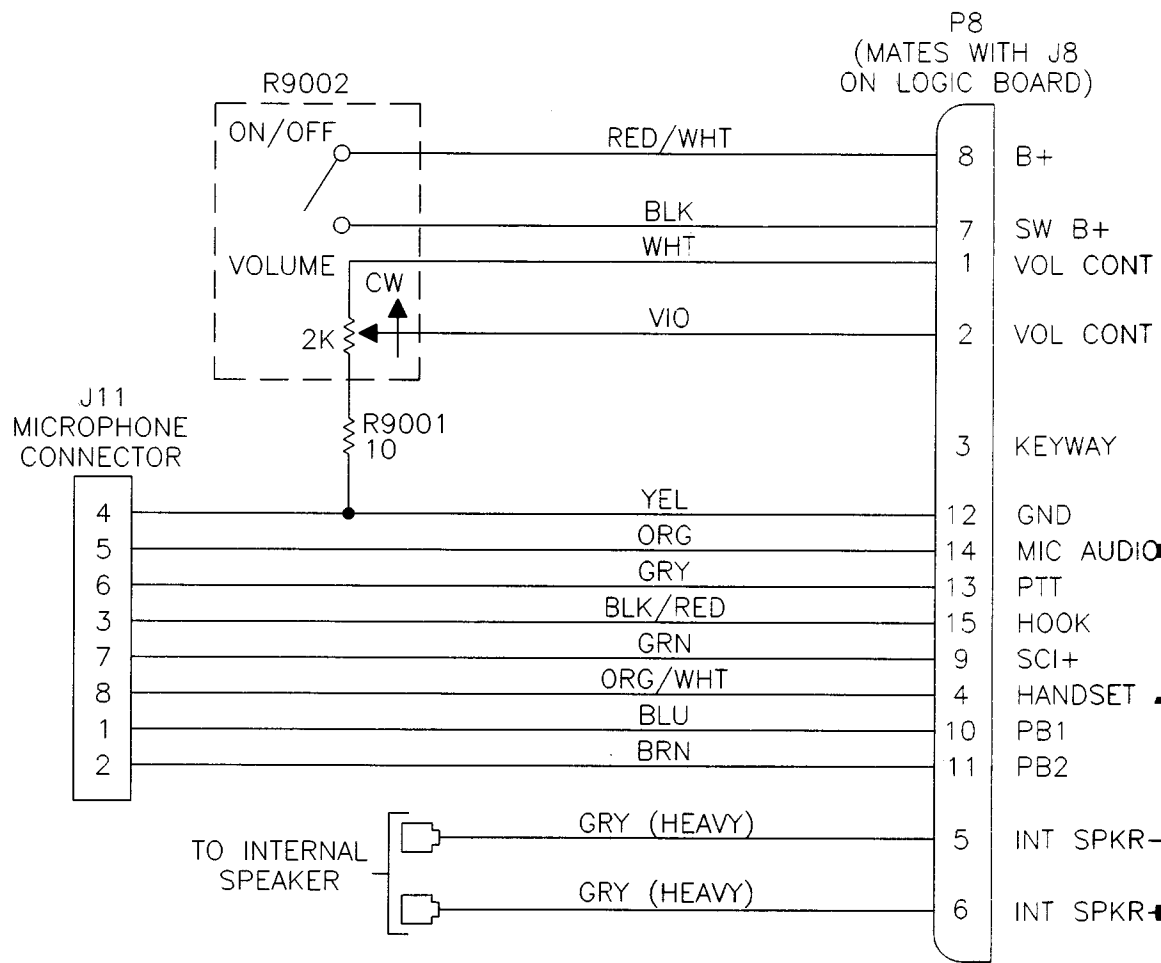
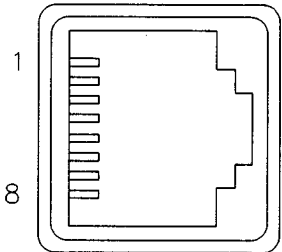

RPD

P8
 (MATES WITH J8
 ON LOGIC BOARD)

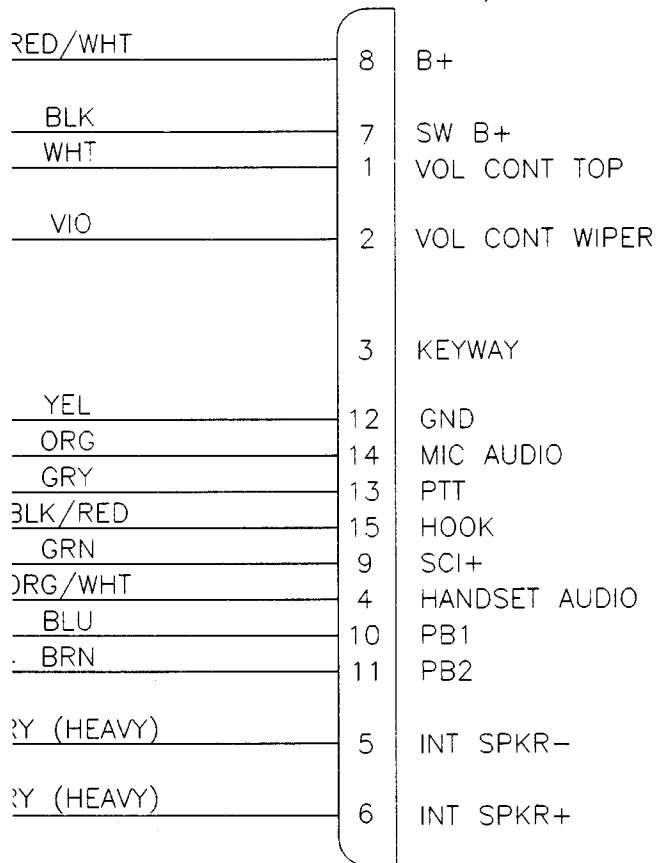

RPD-92116-0

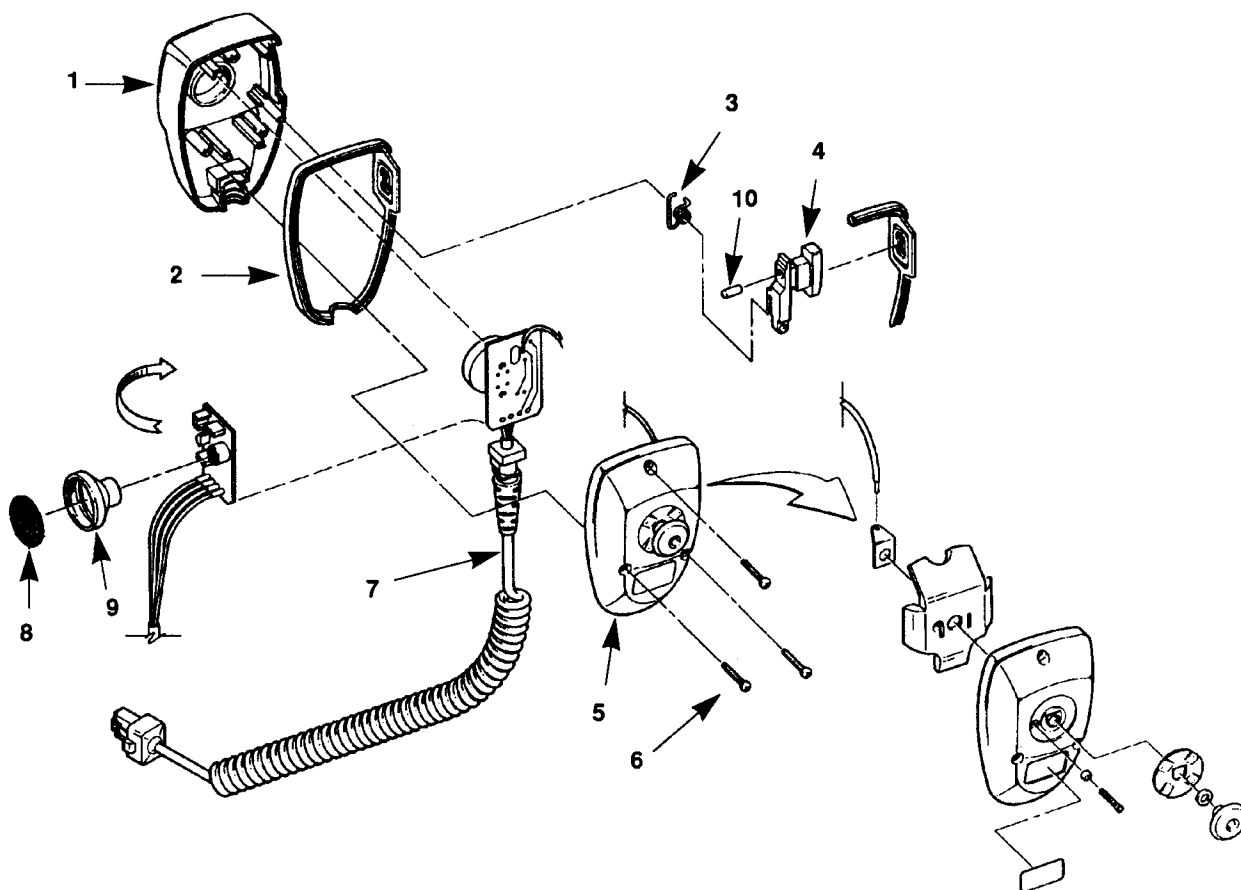

parts list

HMN3596A: MICROPHONE EXPLODED VIEW PARTS LIST (part of HMN3413A)

REF SYMBOL	MOTOROLA PART NUMBER	DESCRIPTION	QTY. USED
1	15-80566B02	FRONT HOUSING	1
2	32-80565B01	GASKET, MICROPHONE	1
3	41-80150R01	SPRING	1
4	38-80568B01	PTT BUTTON	1
5	01-80704Y99	REAR HOUSING RIVETED	1
6	03-11994A23	SCREWS 5-20 x 7/8	3
7	30-80978Z03	COIL CORD, MICROPHONE	1
8	35-80132R01	FELT, BAFFLE, MICROPHONE	1
9	05-80149R01	GROMMET, MIC.	1
10	75-80983Z02	RUBBER SPACER, SWITCH	1

Exploded View, Schematic, Circuit Board
Detail and Parts List for Microphone

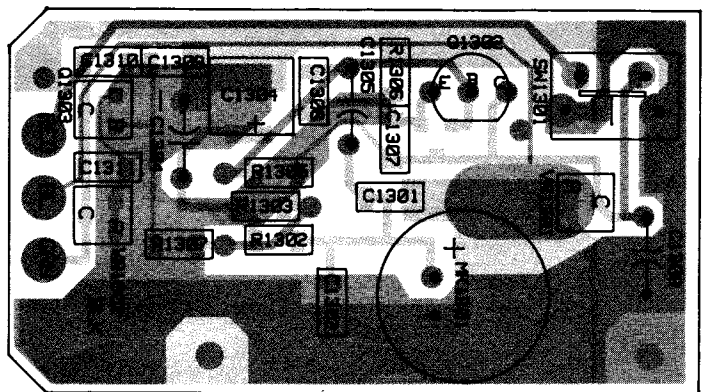
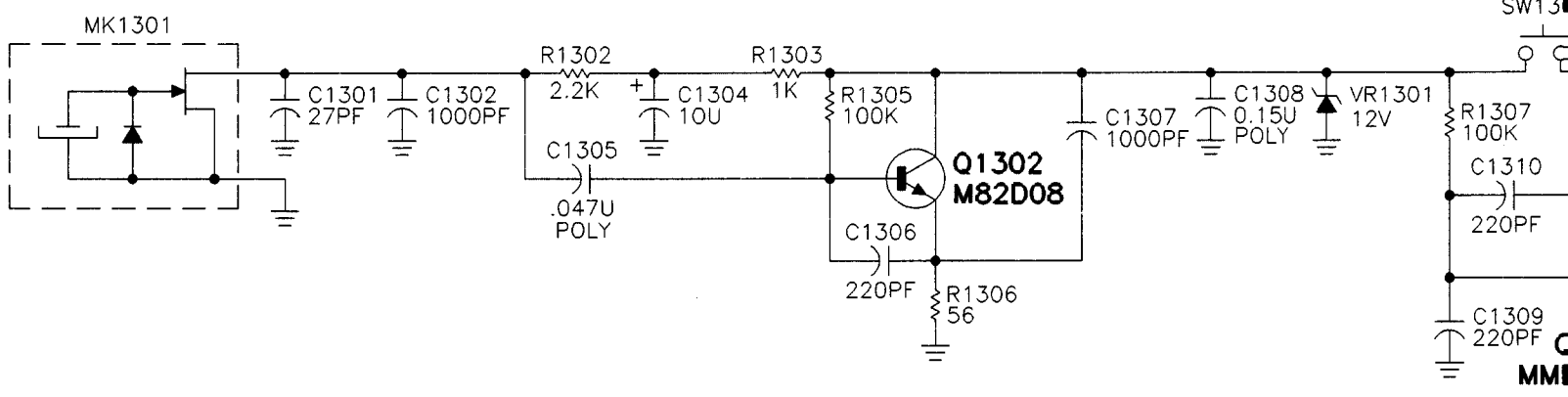

● COMPONENT SIDE
 ● SOLDER SIDE

SHOWN FROM COMPONENT SIDE

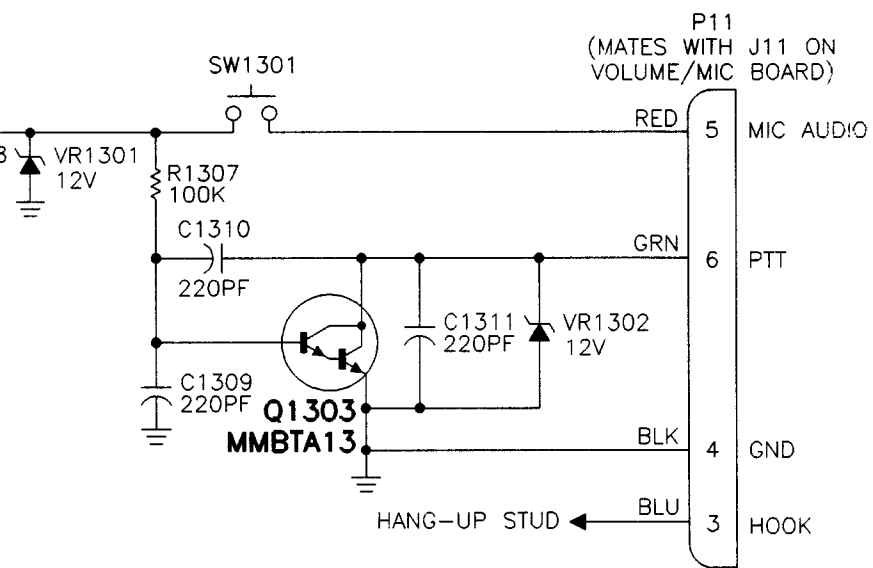

RPD-92117-0



FRONT SIDE ●
REAR SIDE ●

01-80704Y98 Microphone Board
(Used in HMN3596A Microphone)

REFERENCE NUMBER	MOTOROLA PART NO.	DESCRIPTION
------------------	-------------------	-------------

Capacitors, chip, 5%, 50V unless otherwise indicated

C1301	21-13740B35	27 pF
C1302	21-13740B73	1000 pF
C1304	23-11049J27	tantalum 10 uF 10% 25V
C1305	08-11051A11	poly .047 uF 63V
C1306	21-13740B57	220 pF
C1307	21-13740B73	1000 pF
C1308	08-11051A14	poly .15 uF 63V
C1309	21-13740B57	220 pF
C1310	21-13740B57	220 pF
C1311	21-13740B57	220 pF

Microphone

MK1301	50-80258E04	cartridge electret
--------	-------------	--------------------

Transistors (see note)

Q1302	48-80182D08	NPN; type M8208
Q1303	48-05128M19	NPN; type MMBTA13

Resistors, chip, 5%, 1/8 watt

R1302	06-11077A82	2.2k
R1303	06-11077A74	1k
R1305	06-11077B23	100k
R1306	06-11077A44	56
R1307	06-11077B23	100k

Switch

SW1301	40-80164S01	momentary pushbutton
--------	-------------	----------------------

Voltage regulators (see note)

VR1301	48-80140L17	zener diode 12V 5% SOT
VR1302	48-80140L17	zener diode 12V 5% SOT

Note: For optimum performance, diodes, transistors, and integrated circuits must be ordered by Motorola part numbers.

3/12/92

PL-921020-O

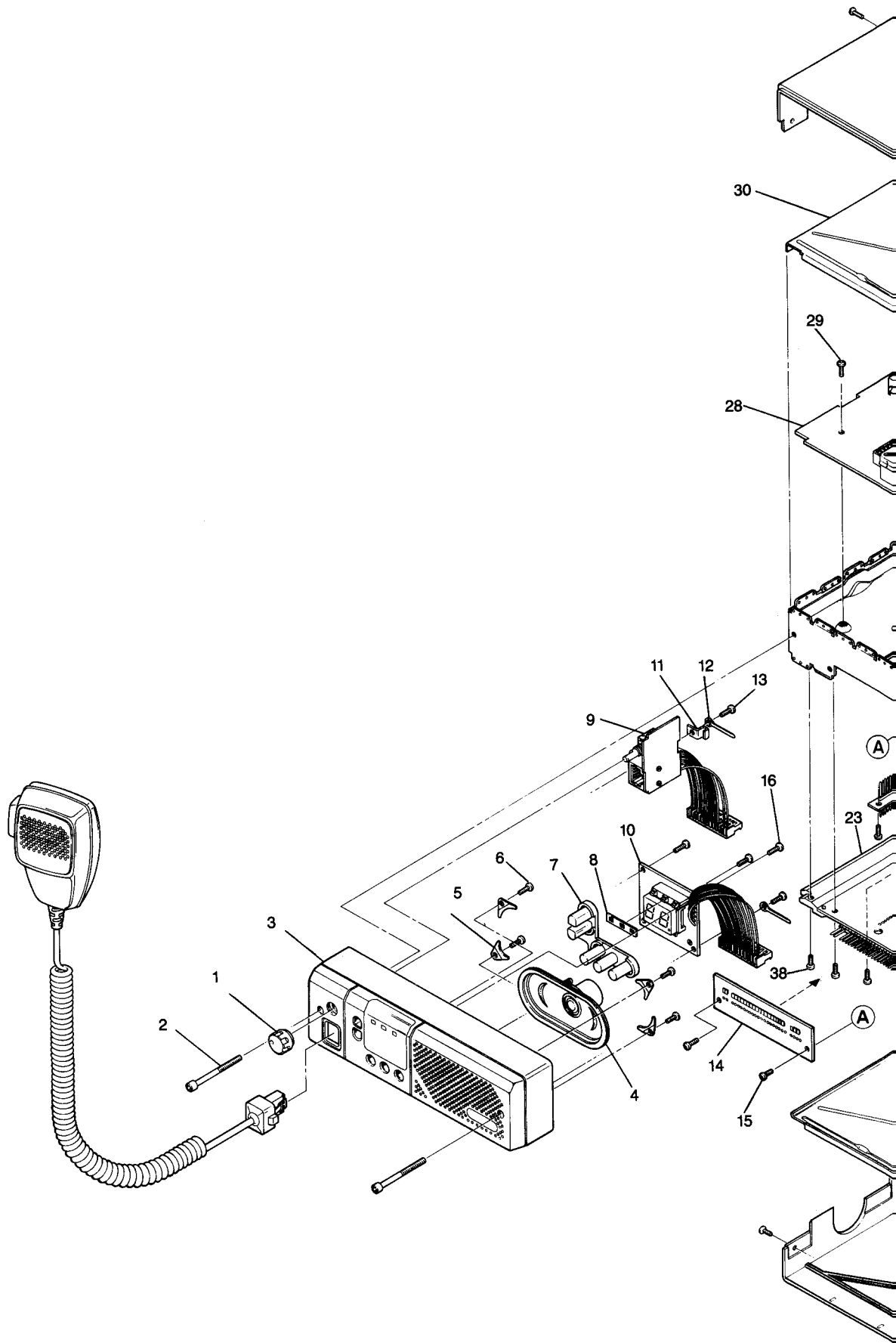

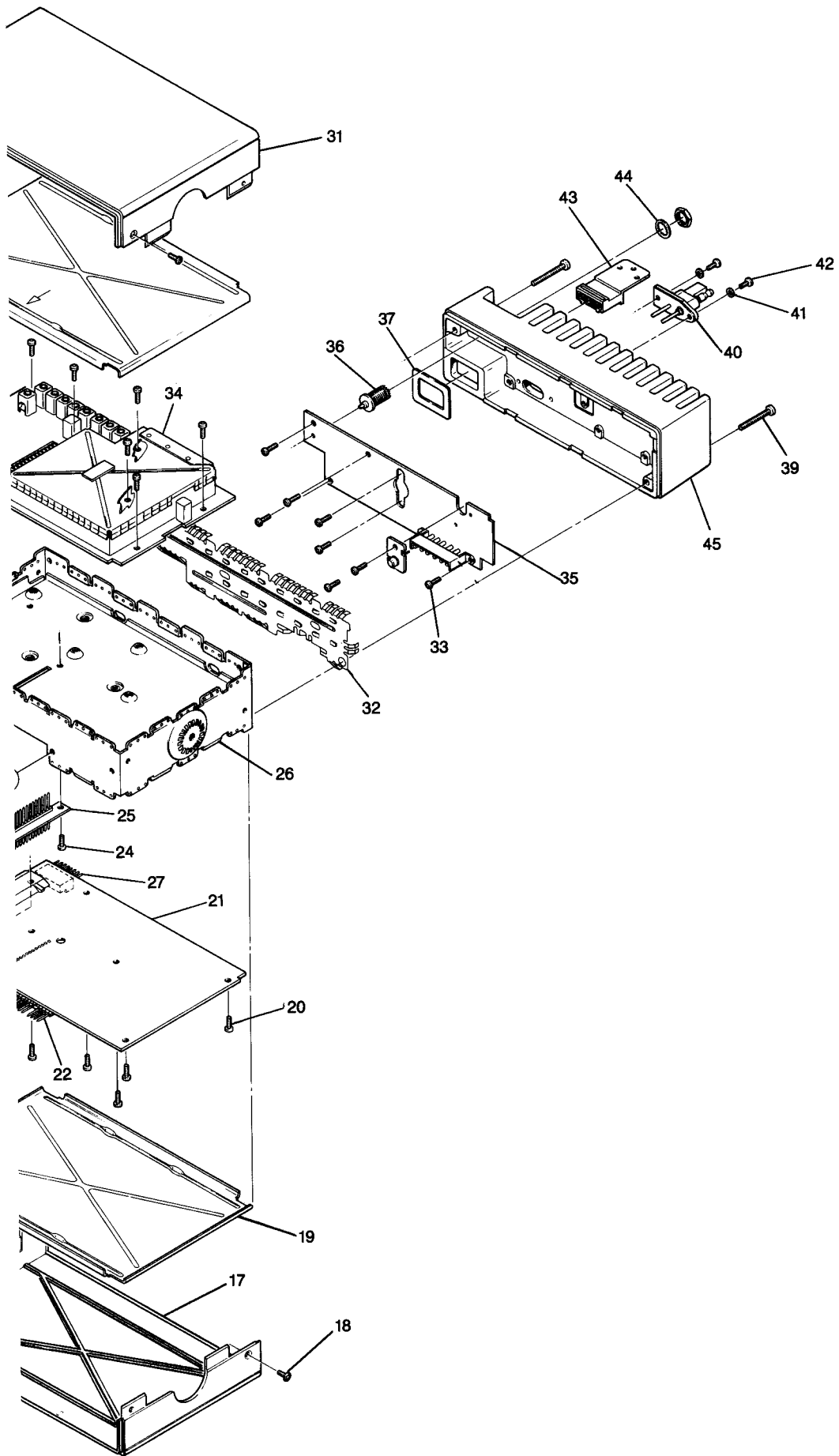

parts list

(GM300 Mobile Radio exploded view)

REF SYMBOL	MOTOROLA PART NUMBER	DESCRIPTION	QTY. USED
1	36-80106M03	Knob, Control	1
2	03-80270L01	Screw, M4 x .7 x 38 cap blk	2
3	15-80516B01	Housing, Front-Panel	1
4	50-80085D03	Speaker	1
5	42-80253L01	Bracket, speaker	4
6	03-10945A11	Screw, M3 x 8 plastite	4
7	75-80517B01	Keypad, elastrometric	1
8	32-80039M01	Gasket, LED	1
9	HLN8071A	Vol/Mic. cable assembly	1
10	HLN8075A	Display PCB assembly	1
11	07-89037M01	Bracket, PCB retainer	1
12	29-00129883	Lug	1
13	03-10945A11	Screw, M3 x 8 plastite	1
14	01-80704Y83	Front Panel Filter PCB	1
15	03-10943M09	Screw, M3 x 6	2
16	03-10945A11	Screw, M3 x 8 plastite	4
17	15-80127L01	Cover, housing	1
18	03-10943R55	Screw, M3 x 8	4
19	26-80498B01	Shield, chassis	1
20	03-10943M09	Screw, M3 x 6	6
21	-----	Logic Bd. (See model chart)	1
22	28-80600B01	Connector, 27 pin, J8 & J9	1
23	26-80497B01	Heatsink, logic bd	1
24	03-10943M09	Screw, M3 x 6	2
25	01-80605B01	Feed-thru assembly, RF/Logic	1
26	27-80496B01	Chassis	1
27	28-80923V01	Connector, 16 pin	1
28	-----	RF Bd. (See model chart)	1
29	03-10943M09	Screw, M3 x 6	7
30	26-80498B01	Shield, chassis	1
31	15-80127L01	Cover, housing	1
32	26-80223M07	Shield, PA	1
33	03-10943M10	Screw, M3 x 8	8
34	26-80229L03	Shield, VCO	1
35	-----	(Part of P.A. assembly)	1
36	09-80131M01	Antenna connector, mini UHF	1
37	32-80014N03	Gasket, accessory conn.	1
38	03-10943M10	Screw, M3 x 8	2
39	03-80271L01	Screw, M4 x 27	2
40	09-80255E01	Power connector	1
41	04-05587G01	Washer, power conn.	1
42	03-10943M11	Screw, M3 x 10	2
43	01-80701Y58	Connector assembly	1
44	04-80943V01	Lock-washer, ant.conn.	1
45	26-80124L01	Heatsink, P.A.	1

HLD8029A RF Board, 146-174 MHz, 12.5 kHz (N)
HLD8031A RF Board, 146-174 MHz, 25 kHz (W)

REFERENCE NUMBER	MOTOROLA PART NO.	DESCRIPTION
------------------	-------------------	-------------

Capacitor, chip, 5%, 50V unless otherwise indicated.

C1	21-13740B30	16 pF	C112		not used
C2	21-13740B38	36 pF	C113	21-13741B69	.1 uF
C3	21-13740B36	30 pF	C114	21-13740B73	1000 pF
C4	21-13740B30	16 pF	C115	21-13741B45	.01 uF
C5		not used	C116	21-13740B73	1000 pF
C6	21-13740B13	3.3 +/- .25 pF	C117	21-13740B73	1000 pF
C7	21-13740B13	3.3 +/- .25 pF	C118	21-13740B31	18 pF
C8	21-13740B25	10 pF	C119	21-13740B73	1000 pF
C9	21-13740B37	33 pF	C120	21-13740B73	1000 pF
C10	21-13740B38	36 pF	C121	21-13740B29	15 pF
C11	21-13740B33	22 pF	C122	21-13740B49	100 pF
C12	21-13740B65	470 pF	C127		not used
C13	21-13740B32	20 pF	C151	21-13740B73	1000 pF
C14	21-13740B45	68 pF	C152	21-13740B47	82 pF
C15	21-13740B43	56 pF	C153	21-13740B25	10 pF
C16	21-13740B34	24 pF	C154	21-13741B45	.01 uF
C17	21-13740B42	51 pF	C155	21-13740B55	180 pF
C18	21-13740B27	12 pF	C156	21-13740B55	180 pF
C19	21-13740B65	470 pF	C157	21-13741B45	.01 uF
C20	21-11032B15	.22 uF +80/-20%	C158	08-11051A15	poly .22 uF 63V
C21	21-11032B15	.22 uF +80/-20%	C159	21-13740B35	27 pF
C22	21-13741B45	.01 uF	C160	21-13740B29	15 pF
C23	21-13741B45	.01 uF	C161	21-13740B73	1000 pF
C51	21-13740B35	27 pF	C162	23-11048B13	lytic 10 uF 20% 16V
C52	21-13740B35	27 pF	C163	08-11051A17	poly .47 uF 63V
C53	21-13740B18	5.1 +/- .25 pF	C164	21-13741B69	.1 uF
C54	21-13740B47	82 pF	C165	21-13740B73	1000 pF
C55	21-13741B45	.01 uF	C166	21-13740B49	100 pF
C56	21-13741B45	.01 uF	C167	21-13740B49	100 pF
C57	21-13740B29	15 pF	C168	21-13740B49	100 pF
C58	21-13740B25	10 pF	C169		not used
C59	21-13740B29	15 pF	C176	21-13740B73	1000 pF
C60	21-13741B45	.01 uF	C177	21-13741B69	.1 uF
C61	21-13741B45	.01 uF	C201	23-11048B13	lytic 10 uF 20% 16V
C65	21-11032B15	.22 uF +80/-20%	C205	21-13741B49	.015 uF
C66	21-13741B45	.01 uF	C206	21-13740B27	12 pF
C67	23-13749C39	tantalum 10 uF 10% 20V	C207	21-13740B29	15 pF
C68	21-13740B33	22 pF	C208	21-13740B27	12 pF
C69	21-13740B39	39 pF	C209	21-13740B23	8.2 +/- .25 pF
C70	21-13740B29	15 pF	C210	21-13740B73	1000 pF
C71	21-11032B15	.22 uF +80/-20%	C211	21-13740B73	1000 pF
C72	21-11032B15	.22 uF +80/-20%	C212	21-13740B73	1000 pF
C73	23-13749C39	tantalum 10 uF 10% 20V	C213	21-13740B19	5.6 +/- .25 pF
C74	23-11048B13	lytic 10 uF 20% 16V	C214	21-13740B13	3.3 +/- .25 pF
C75	21-13741B69	.1 uF	C215	21-13740B73	1000 pF
C76	23-11048B05	lytic 1 uF 20% 50V	C216	21-13740B47	82 pF
C77	21-11032B15	.22 uF +80/-20%	C217		not used
C78	21-11032B15	.22 uF +80/-20%	C218	21-13741B45	.01 uF
C79	21-13741B29	.0022 uF	C219	21-13740B13	3.3 +/- .25 pF
C80	21-11032B15	.22 uF +80/-20%	C220	21-13740B73	1000 pF
C81	21-13740B55	180 pF	C221	21-13740B05	1.5 +/- .25 pF
C82	21-11032B15	.22 uF +80/-20%	C222	21-13741B45	.01 uF
C83	21-11032B15	.22 uF +80/-20%	C223	21-13740B13	3.3 +/- .25 pF
C84	21-13740B09	2.2 +/- .25 pF	C224	21-13740B73	1000 pF
C85	21-13740B27	12 pF	C225	21-13740B73	1000 pF
C86		not used	C228	21-13740B80	2200 pF
C87	21-13741B45	.01 uF	C229	21-13740B05	1.5 +/- .25 pF
C88	21-11032B15	.22 uF +80/-20%	C230	21-13740B05	1.5 +/- .25 pF
C89		not used	C231	21-13740B38	36 pF
C101	23-11048B13	lytic 10 uF 20% 16V	C232		not used
C102	08-11051A13	poly .1 uF 63V	C233	21-13740B40	43 pF
C103	21-13741B45	.01 uF	C234	21-13740B29	15 pF
C104	21-13741B45	.01 uF	C235	21-13740B23	8.2 +/- .25 pF
C105	23-11048B13	lytic 10 uF 20% 16V	C236	21-13740B23	8.2 +/- .25 pF
C106	21-13740B29	15 pF	C237	21-13740B73	1000 pF
C107	21-13741B69	.1 uF	C238	21-13740B73	1000 pF
C108	21-13741B69	.1 uF	C239	21-13740B73	1000 pF
C109	08-11051A13	poly .1 uF 63V	C240	21-13740B13	3.3 +/- .25 pF
C110	08-11051A19	poly 1 uF 63V	C241	21-13740B19	5.6 +/- .25 pF
C111	08-11051A09	poly .022 uF 63V	C242	21-13740B73	1000 pF
			C243	21-13740B47	82 pF
			C244		not used
			C245	21-13740B73	1000 pF
			C246	21-13740B25	10 pF
			C247	21-13740B73	1000 pF
			C248	21-13740B01	1 +/- .25 pF
			C249	21-13741B45	.01 uF
			C250	21-13740B17	4.7 +/- .25 pF

C251	21-13740B73	1000 pF
C252	21-13740B73	1000 pF
C253		not used
C256	21-13741B45	.01 uF
C258	08-11051A08	poly .015 uF 63V
C276	21-13741B45	.01 uF
C277	23-11048B19	lytic 47 uF 20% 16V
C278	23-11048B19	lytic 47 uF 20% 16V
C301	21-13741B45	.01 uF
C302		not used
C303	21-13740B65	470 pF
C304		not used
C305		not used
C306		not used
C307		not used
C308		not used
C309		not used
C310		not used
C311		not used
C312		not used
C313		not used

Diodes (see note)

CR2	48-80154K03	dual Schottky SOT
CR5	48-80142L01	silicon PIN SOT MMBV3401
CR51	48-05129M76	silicon SOT
CR52	48-05129M76	silicon SOT
CR101	48-05129M76	silicon SOT
CR102	48-05129M76	silicon SOT
CR151	48-80006E10	silicon varactor SOT
CR152	48-80006E10	silicon varactor SOT
CR153	48-84336R03	dual silicon SOT MMBD7000
CR202	48-80006E11	silicon varactor SOT
CR203	48-80006E11	silicon varactor SOT
CR204	48-80006E11	silicon varactor SOT
CR205	48-80006E11	silicon varactor SOT
CR206	48-80154K03	dual Schottky SOT
CR209	48-80006E10	silicon varactor SOT
CR210	48-80006E11	silicon varactor SOT
CR211	48-80006E11	silicon varactor SOT
CR212	48-80006E11	silicon varactor SOT
CR213	48-80006E11	silicon varactor SOT
CR214	48-80154K03	dual Schottky SOT

Filters

FL51(N)	91-80097D04	455 kHz 6F
FL51(W)	91-80097D06	455 kHz 6D
FL52(N)	91-80098D04	455 kHz 4F
FL52(W)	91-80098D06	455 kHz 4D

Connector, receptacle

J4	09-80135M01	coaxial (RX)
J5	09-80135M01	coaxial (TX)
J6	09-80130M03	14-pin, RF board

Coils

L1	24-62587E51	chip 68 nH 5%
L2	24-62587E51	chip 68 nH 5%
L3	24-62587E51	chip 68 nH 5%
L4	24-62587E51	chip 68 nH 5%
L5	24-62587E51	chip 68 nH 5%
L6	24-62587E51	chip 68 nH 5%
L7	24-62587E51	chip 68 nH 5%
L8	24-62587E69	chip 1.2 uH 5%
L10	24-62587E69	chip 1.2 uH 5%
L11	24-62587E51	chip 68 nH 5%
L51	24-62587E61	chip .47 uH 5%
L52	24-62587E61	chip .47 uH 5%
L53	24-62587E61	chip .47 uH 5%
L54	24-62587E76	chip 4.7 uH 5%
L55	24-80164M02	tunable .7 uH E715
L56	24-80164M01	tunable .7 uH E713
L57	24-80164M04	tunable .7 uH E714
L58	24-62587E76	chip 4.7 uH 5%

L59	24-80164M03	tunable .7 uH E716
L60	24-62587E69	chip 1.2 uH 5%
L61	25-80000E01	tunable 455 kHz with cap
L101	24-62587E69	chip 1.2 uH 5%
L102	24-62587E47	chip 33 nH 5%
L103	24-62587E76	chip 4.7 uH 5%
L151	24-80299D01	tunable 17-3/4 turns
L152	24-11087A35	chip 5.6 uH 10%
L202	24-80148M05	tunable 3-1/2 turns
L203	24-62587E69	chip 1.2 uH 5%
L204	24-62587E47	chip 33 nH 5%
L205	24-62587E69	chip 1.2 uH 5%
L206	24-62587E69	chip 1.2 uH 5%
L207	24-62587E69	chip 1.2 uH 5%
L208	24-62587E47	chip 33 nH 5%
L209	24-62587E56	chip .18 uH 5%
L210	24-62587E52	chip 82 nH 5%
L211	24-62587E69	chip 1.2 uH 5%
L213	24-80148M08	tunable 4-1/2 turns
L214	24-62587E69	chip 1.2 uH 5%
L215	24-62587E52	chip 82 nH 5%
L216	24-62587E69	chip 1.2 uH 5%
L217	24-62587E69	chip 1.2 uH 5%
L218	24-62587E69	chip 1.2 uH 5%
L219	24-62587E47	chip 33 nH 5%
L220	24-62587E56	chip .18 uH 5%
L221	24-62587E54	chip .12 uH 5%
L222	24-62587E69	chip 1.2 uH 5%
L301	24-84657R01	ferrite bead

Transistors (see note)

Q1	48-80950X01	NPN; type M50X01
Q2	48-05128M67	PNP; type MMBT3906
Q5	48-05128M67	PNP; type MMBT3906
Q6	48-80214G02	NPN; type MMBT3904
Q51	48-05128M66	field effect; type MMBFU310
Q52	48-05128M66	field effect; type MMBFU310
Q53	48-80214G02	NPN; type MMBT3904
Q101	48-05128M67	PNP; type MMBT3906
Q102	48-80182D20	NPN; type M82D20/M9987
Q103	48-80182D20	NPN; type M82D20/M9987
Q104	48-05128M67	PNP; type MMBT3906
Q105	48-80214G02	NPN; type MMBT3904
Q106	48-80214G02	NPN; type MMBT3904
Q107	48-11043C19	NPN; type M43C19/M9658
Q151	48-11043C19	NPN; type M43C19/M9658
Q152	48-11043C06	PNP; type M43C06/M9643
Q203	48-05128M66	field effect; type MMBFU310
Q204	48-11043C19	NPN; type M43C19/M9658
Q205	48-11043C19	NPN; type M43C19/M9658
Q206	48-05128M66	field effect; type MMBFU310
Q207	48-11043C19	NPN; type M43C19/M9658
Q208	48-11043C19	NPN; type M43C19/M9658
Q276	48-80214G02	NPN; type MMBT3904
Q277	48-05128M67	PNP; type MMBT3906
Q278	48-05128M67	PNP; type MMBT3906
Q279	48-05128M67	PNP; type MMBT3906

Resistors, chip, 5%, 1/10 watt, unless otherwise indicated.

R1	06-11077A30	15
R2		not used
R3		470
R4	06-11077A66	2.7k
R5	06-11077A84	180
R6	06-11077A56	180
R7	06-11077A98	10k
R7	06-11077A96	8.2k
R8	06-11077A98	10k
R9	06-11077A90	4.7k
R10	06-11077B07	22k
R11	06-11077B15	47k
R12	06-11077A50	100
R13	06-11077A68	560
R51	06-11077A43	51
R52	06-11077A54	150
R53	06-11077A88	3.9k
R54	06-11077A54	150

R56	06-11077B45	820k
R57	06-11077A72	820
R58	06-11077B23	100k
R59	06-11077B27	150k
R60	18-05500L08	variable 22k
R61(N)	06-11077B07	22k
R61(W)	06-11077B19	68k
R62(N)	06-11077A26	10
R62(W)	06-11077B09	27k
R63	06-11077B21	82k
R102	06-11077A62	330
R103	06-11077A98	10k
R104	06-11077A98	10k
R105	06-11077B11	33k
R106	06-11077A74	1k
R107	06-11077A78	1.5k
R108	06-11077A26	10
R109	06-11077A26	10
R110	06-11077B03	15k
R111	06-11077A72	820
R112	06-11077A86	3.3k
R113	06-11077A74	1k
R114	06-11077A72	820
R115	06-11077A70	680
R116	06-11077A92	5.6k
R118	06-11077A70	680
R119	06-11077A90	4.7k
R120	06-11077A88	3.9k
R121	06-11077A88	3.9k
R122	06-11077A43	51
R123	06-11077A50	100
R124	06-11077A84	2.7k
R125	06-11077A72	820
R151	06-11077B15	47k
R152	06-11077B11	33k
R153	06-11077B15	47k
R154	06-11077A34	22
R155	06-11077A98	10k
R156	06-11077B03	15k
R157	06-11077A78	1.5k
R158	06-11077A74	1k
R159	06-11077A74	1k
R160		not used
R161	06-11077A98	10k
R162		not used
R163(N)	06-11077B11	33k
R163(W)	06-11077B03	15k
R164	18-05500L08	variable 22k
R165(N)	06-11077A98	10k
R165(W)	06-11077B17	56k
R176	06-11077G26	22.6k 1%
R177	06-11077G18	18.7k 1%
R178	06-11077F91	10.0k 1%
R179	06-11077F91	10.0k 1%
R180	06-11077G52	42.2k 1%
R181	06-11077F91	10.0k 1%
R182	06-11077G28	23.7k 1%
R207	06-11077A44	56
R208	06-11077A44	56
R209	06-11077A50	100
R210	06-11077A84	2.7k
R211	06-11077A98	10k
R212	06-11077A84	2.7k
R213	06-11077A72	820
R214	06-11077A50	100
R215	06-11077A84	2.7k
R216	06-11077A72	820
R217	06-11077A42	47
R218	06-11077A54	150
R219	06-11077A40	39
R220	06-11077A54	150
R222	06-11077A88	3.9k
R223(N)	06-11077A92	5.6k
R223(W)	06-11077A66	470
R224	06-11077B23	100k
R225(N)	06-11077A92	5.6k
R225(W)	06-11077B01	12k
R226	06-11077A44	56

R227	06-11077A44	56
R228	06-11077A50	100
R229	06-11077A84	2.7k
R230	06-11077A98	10k
R231	06-11077A84	2.7k
R232	06-11077A72	820
R233	06-11077A50	100
R234	06-11077A84	2.7k
R235	06-11077A72	820
R236	06-11077A42	47
R237	06-11077A66	470
R238	06-11077A28	12
R239	06-11077A66	470
R241	06-11077B23	100k
R276	06-11077A98	10k
R277	06-11077A60	270
R278	06-11077A26	10
R279	06-11077A90	4.7k
R280	06-11077A98	10k
R281	06-11077A90	4.7k
R301	06-11077A74	1k
R302	18-05500L08	variable 22k
R303	06-11077B01	12k

Transformers

T1	25-80163M02	balun
T2	25-80163M02	balun

Integrated circuits and modules (see note)

U1	48-80174R01	quad Schottky ring SOIC
U51	51-05479G05	receiver system
U101	51-84704M75	synthesizer
U102	51-84810F66	prescaler
U176	51-80932W01	dual op-amp

Voltage regulators (see note)

VR176	48-82256C11	zener diode 10V 5%
-------	-------------	--------------------

Crystals

Y51(N)	91-80022M03	filter 45.1 MHz 12.5 kHz
Y51(W)	91-80022M02	filter 45.1 MHz 25 kHz
Y52	48-80008K02	44.645 MHz
Y151	48-80174D05	14.4 MHz

Non-referenced items

26-80097M01	shield coil can (for L151)
26-80098M01	shield coil can (10 used)
26-80228L01	shield can (2 used, for J4 and J5)
26-80229L03	shield VCO frame
75-05295B02	insulator (for Y151)
75-05295B05	insulator (3 used, for Y51A/B, Y52)

Note: For optimum performance, diodes, transistors, and integrated circuits must be ordered by Motorola part numbers.

3/10/92

PL-921009-O

HLE8030A RF Board, 449-470 MHz, 12.5 kHz (N)
HLE8032A RF Board, 449-470 MHz, 25 kHz (W)

REFERENCE NUMBER	MOTOROLA PART NO.	DESCRIPTION
------------------	-------------------	-------------

Capacitor, chip, 5%, 50V unless otherwise indicated.

C1	21-13740B17	4.7 +/- .25 pF
C2	21-13740B14	3.6 +/- .25 pF
C3	21-13740B14	3.6 +/- .25 pF
C4	21-13740B25	10 pF
C5	21-13740B14	3.6 +/- .25 pF
C6	21-13740B15	3.9 +/- .25 pF
C7	21-13740B27	12 pF
C8	21-13740B16	4.3 +/- .25 pF
C9	21-13740B14	3.6 +/- .25 pF
C10	21-13740B21	6.8 +/- .25 pF
C11	21-13740B29	15 pF
C12	21-13740B45	68 pF
C13	21-13740B27	12 pF
C14	21-13740B23	8.2 +/- .25 pF
C15	21-13740B15	3.9 +/- .25 pF
C16	21-13740B13	3.3 +/- .25 pF
C17	21-13740B27	12 pF
C18	21-13740B13	3.3 +/- .25 pF
C19	21-13740B13	3.3 +/- .25 pF
C20	21-13740B32	20 pF
C21	21-13740B13	3.3 +/- .25 pF
C22	21-13740B13	3.3 +/- .25 pF
C23	21-13740B29	15 pF
C24	21-13740B16	4.3 +/- .25 pF
C25	21-13740B14	3.6 +/- .25 pF
C26	21-13740B23	8.2 +/- .25 pF
C27	21-11032B15	.22 uF +80/-20%
C28	21-13740B45	68 pF
C29	21-13740B45	68 pF
C30	21-11032B15	.22 uF +80/-20%
C33		not used
C51	21-13740B55	180 pF
C52	21-13740B27	12 pF
C53	21-13740B47	82 pF
C54	21-13740B61	330 pF
C55	21-13741B45	.01 uF
C56	21-13741B45	.01 uF
C57(N)	21-13740B29	15 pF
C57(W)	21-13740B31	18 pF
C58(N)	21-13740B25	10 pF
C58(W)	21-13740B27	12 pF
C59(N)	21-13740B29	15 pF
C59(W)	21-13740B31	18 pF
C60	21-13741B45	.01 uF
C61	21-13741B45	.01 uF
C65	21-11032B15	.22 uF +80/-20%
C66	21-13741B45	.01 uF
C67	23-13749C39	tantalum 10 uF 10% 20V
C68	21-13740B33	22 pF
C69	21-13740B39	39 pF
C70	21-13740B29	15 pF
C71	21-11032B15	.22 uF +80/-20%
C72	21-11032B15	.22 uF +80/-20%
C73	23-13749C39	tantalum 10 uF 10% 20V
C74	23-11048B13	lytic 10 uF 20% 16V
C75	21-13741B69	.1 uF
C76	23-11048B05	lytic 1 uF 20% 50V
C77	21-11032B15	.22 uF +80/-20%
C78	21-11032B15	.22 uF +80/-20%
C79	21-13741B29	.0022 uF
C80	21-11032B15	.22 uF +80/-20%
C81	21-13740B55	180 pF
C82	21-11032B15	.22 uF +80/-20%
C83	21-11032B15	.22 uF +80/-20%
C84	21-13740B09	2.2 +/- .25 pF
C85	21-13740B27	12 pF
C86	21-13740B39	39 pF
C87	21-11032B15	.22 uF +80/-20%
C101	23-11048B13	lytic 10 uF 20% 16V
C102	08-11051A13	poly .1 uF 63V

C103	21-13741B45	.01 uF
C104	21-13741B45	.01 uF
C105	23-11048B13	lytic 10 uF 20% 16V
C106	21-13740B29	15 pF
C107	21-13741B69	.1 uF
C108	21-13741B69	.1 uF
C109	08-11051A13	poly .1 uF 63V
C110	08-11051A19	poly 1 uF 63V
C111	08-11051A09	poly .022 uF 63V
C112	08-11051A01	poly .001 uF 63V
C113	21-13741B45	.01 uF
C114	21-13740B45	68 pF
C115	21-13741B45	.01 uF
C116	21-13740B49	100 pF
C117	21-13741B69	.1 uF
C118	21-13740B45	68 pF
C119	21-13740B45	68 pF
C120	21-13740B45	68 pF
C121	21-13740B19	5.6 +/- .25 pF
C122	21-13740B49	100 pF
C123	21-13740B45	68 pF
C124	21-13740B25	10 pF
C125	21-13740B73	1000 pF
C126		not used
C127	21-11032B15	.22 uF +80/-20%
C128	21-11032B15	.22 uF +80/-20%
C129		not used
C130	21-11032B15	.22 uF +80/-20%
C151	21-13740B73	1000 pF
C152	21-13740B47	82 pF
C153	21-13740B25	10 pF
C154	21-13741B45	.01 uF
C155	21-13740B55	180 pF
C156	21-13740B55	180 pF
C157		not used
C158	08-11051A15	poly .22 uF 63V
C159	21-13740B35	27 pF
C160	21-13740B29	15 pF
C161	21-13740B73	1000 pF
C162	23-11048B13	lytic 10 uF 20% 16V
C163	08-11051A17	poly .47 uF 63V
C164		not used
C165	21-13741B33	.0033 uF
C176	21-13740B73	1000 pF
C201	23-11048B13	lytic 10 uF 20% 16V
C205	21-13740B45	68 pF
C206	21-13740B19	5.6 +/- .25 pF
C207	21-13740B27	12 pF
C208	21-13740B23	8.2 +/- .25 pF
C209	21-13740B23	8.2 +/- .25 pF
C210	21-13740B49	100 pF
C212	21-13740B49	100 pF
C213	21-13740B01	1 +/- .25 pF
C214	21-13740B13	3.3 +/- .25 pF
C215	21-13740B49	100 pF
C216	21-13740B13	3.3 +/- .25 pF
C218	21-13740B49	100 pF
C220	21-13740B23	8.2 +/- .25 pF
C221	21-13740B05	1.5 +/- .25 pF
C222	21-13740B49	100 pF
C224	21-13740B49	100 pF
C225	21-13740B49	100 pF
C228	21-13741B29	.0022 uF
C230	21-13740B01	1 +/- .25 pF
C231	21-13740B01	1 +/- .25 pF
C233	21-13740B11	2.7 +/- .25 pF
C234	21-13740B21	6.8 +/- .25 pF
C235	21-13740B17	4.7 +/- .25 pF
C236	21-13740B15	3.9 +/- .25 pF
C237	21-13740B45	68 pF
C239	21-13740B45	68 pF
C240	21-13740B01	1 +/- .25 pF
C242	21-13740B45	68 pF
C243	21-13740B09	2.2 +/- .25 pF
C244	21-11032B15	.22 uF +80/-20%
C245	21-13740B45	68 pF
C247	21-13740B29	15 pF
C248	21-13740B19	5.6 +/- .25 pF

C249	21-13740B45	68 pF
C251	21-13740B45	68 pF
C252	21-13740B45	68 pF
C253	21-13740B45	68 pF
C255		not used
C256	21-13741B45	.01 uF
C257	21-13741B45	.01 uF
C258	08-11051A07	poly .01 uF 63V
C259	21-13740B22	7.5 +/- .25 pF
C260		not used
C261	21-13741B45	.01 uF
C262		not used
C263	21-13740B19	5.6 +/- .25 pF
C264		not used
C265		not used
C266	21-13740B03	1.2 +/- .25 pF
C267	21-13740B01	1 +/- .25 pF
C268	21-13740B13	3.3 +/- .25 pF
C269	21-13740B09	2.2 +/- .25 pF
C270		not used
C271		not used
C272	21-13740B45	68 pF
C276	21-13741B45	.01 uF
C277	23-11048B19	lytic 47 uF 20% 16V
C278	23-11048B19	lytic 47 uF 20% 16V
C279	21-13740B45	68 pF
C280	21-11032B15	.22 uF +80/-20%
C301	21-13741B45	.01 uF
C302	21-13740B45	68 pF
C303	21-13740B45	68 pF
C304	21-13740B45	68 pF
C305	21-13740B45	68 pF
C306	21-13740B45	68 pF
C307	21-13740B45	68 pF
C308	21-13740B45	68 pF
C309	21-13740B45	68 pF
C310	21-13740B45	68 pF
C311	21-13740B45	68 pF
C312	21-13740B45	68 pF
C313	21-13740B45	68 pF

Diodes (see note)

CR2	48-80154K03	dual Schottky SOT
CR3	48-80939T01	Schottky SOT
CR5	48-80142L01	silicon PIN SOT MMBV3401
CR51	48-05129M76	silicon SOT
CR52	48-05129M76	silicon SOT
CR101	48-05129M76	silicon SOT
CR102	48-05129M76	silicon SOT
CR151	48-80006E10	silicon varactor SOT
CR152	48-80006E10	silicon varactor SOT
CR153	48-84336R03	dual silicon SOT MMBD7000
CR203	48-84534N02	silicon varactor SOT
CR205	48-84534N02	silicon varactor SOT
CR206	48-80154K02	dual Schottky SOT
CR209	48-84534N02	silicon varactor SOT
CR211	48-84534N02	silicon varactor SOT
CR213	48-84534N02	silicon varactor SOT
CR214	48-80939T01	Schottky SOT

Filters

FL51(N)	91-80097D04	455 kHz 6F
FL51(W)	91-80097D06	455 kHz 6D
FL52(N)	91-80098D04	455 kHz 4F
FL52(W)	91-80098D06	455 kHz 4D

Connector, receptacle

J4	09-80135M01	coaxial (RX)
J5	09-80135M01	coaxial (TX)
J6	09-80130M03	14-pin, RF board

Coils

L1	24-80148M01	tunable 1-1/2 turns BRN
L2	24-80148M01	tunable 1-1/2 turns BRN

L3	24-80148M01	tunable 1-1/2 turns BRN
L4	24-80148M01	tunable 1-1/2 turns BRN
L5	24-80148M01	tunable 1-1/2 turns BRN
L6	24-80148M01	tunable 1-1/2 turns BRN
L7	24-80148M01	tunable 1-1/2 turns BRN
L8	24-11030B04	1-1/2 turns YEL
L9	24-11030B04	1-1/2 turns YEL
L10	24-62587E53	chip .1 uH 5%
L51	24-11030B12	7-1/2 turns YEL
L52	24-62587E68	chip 1 uH 5%
L53	24-62587E56	chip .18 uH 5%
L54	24-62587E76	chip 4.7 uH 5%
L55	24-80164M02	tunable .7 uH E715
L56	24-80164M01	tunable .7 uH E713
L57	24-80164M04	tunable .7 uH E714
L58	24-62587E76	chip 4.7 uH 5%
L59	24-80164M03	tunable .7 uH E716
L60	24-62587E69	chip 1.2 uH 5%
L61	25-80000E01	tunable 455 kHz with cap
L101	24-62587E56	chip .18 uH 5%
L102	24-62587E47	chip 33 nH 5%
L151	24-80299D01	tunable 17-3/4 turns
L152	24-11087A35	chip 5.6 uH 10%
L202	24-80148M01	tunable 1-1/2 turns BRN
L203	24-62587E55	chip .15 uH 5%
L204	24-11030B09	4-1/2 turns BRN
L205	24-62587E55	chip .15 uH 5%
L206	24-62587E55	chip .15 uH 5%
L207	24-62587E57	chip .22 uH 5%
L209	24-11030B05	2-1/2 turns GRN
L210	24-11030B08	4-1/2 turns BRN
L211	24-62587E57	chip .22 uH 5%
L213	24-80148M01	tunable 1-1/2 turns BRN
L214	24-62587E54	chip .12 uH 5%
L215	24-11030B08	4-1/2 turns BRN
L216	24-62587E54	chip .12 uH 5%
L217	24-62587E54	chip .12 uH 5%
L218	24-62587E56	chip .18 uH 5%
L220	24-11030B05	2-1/2 turns GRN
L221	24-11030B08	4-1/2 turns BRN
L222	24-62587E56	chip .18 uH 5%

Transistors (see note)

Q1	48-80950X01	NPN; type M50X01
Q2	48-05128M67	PNP; type MMBT3906
Q3	48-05128M67	PNP; type MMBT3906
Q4	48-05128M67	PNP; type MMBT3906
Q5	48-05128M67	PNP; type MMBT3906
Q6	48-80214G02	NPN; type MMBT3904
Q51	48-05128M66	field effect; type MMBFU310
Q52	48-05128M66	field effect; type MMBFU310
Q53	48-80214G02	NPN; type MMBT3904
Q101	48-05128M67	PNP; type MMBT3906
Q102	48-80182D20	NPN; type M82D20/M9987
Q103	48-80182D20	NPN; type M82D20/M9987
Q104	48-05128M67	PNP; type MMBT3906
Q105	48-80214G02	NPN; type MMBT3904
Q106	48-80214G02	NPN; type MMBT3904
Q107	48-11043C19	NPN; type M43C19/M9658
Q151	48-11043C19	NPN; type M43C19/M9658
Q152	48-11043C06	PNP; type M43C06/M9643
Q203	48-05128M66	field effect; type MMBFU310
Q204	48-80950X01	NPN; type M50X01
Q205	48-80950X01	NPN; type M50X01
Q206	48-05128M66	field effect; type MMBFU310
Q207	48-80950X01	NPN; type M50X01
Q208	48-80950X01	NPN; type M50X01
Q276	48-80214G02	NPN; type MMBT3904
Q277	48-05128M67	PNP; type MMBT3906
Q278	48-05128M67	PNP; type MMBT3906
Q279	48-05128M67	PNP; type MMBT3906

Resistors, chip, 5%, 1/10 watt, unless otherwise indicated.

R1	06-11077A84	2.7k
R2	06-11077A54	150
R3	06-11077A60	270

R4	06-11077B01	12k
R5	06-11077B03	15k
R6	06-11077A90	4.7k
R7	06-11077A98	10k
R8	06-11077A98	10k
R9	06-11077A90	4.7k
R10	06-11077B07	22k
R11	06-11077B15	47k
R12	06-11077A45	62
R13	06-11077A65	430
R51	06-11077A44	56
R52	06-11077A54	150
R53	06-11077A88	3.9k
R54	06-11077A54	150
R56	06-11077B45	820k
R57	06-11077A72	820
R58	06-11077B23	100k
R59	06-11077B27	150k
R60	18-05500L08	variable 22k
R61(N)	06-11077B07	22k
R61(W)	06-11077B19	68k
R62(N)	06-11077A26	10
R62(W)	06-11077B09	27k
R63	06-11077B21	82k
R102	06-11077A62	330
R103	06-11077A98	10k
R104	06-11077A98	10k
R105	06-11077B11	33k
R106	06-11077A73	910
R107	06-11077A78	1.5k
R108	06-11077A26	10
R109	06-11077A26	10
R110	06-11077B03	15k
R111	06-11077A54	150
R112	06-11077A72	820
R113	06-11077A58	220
R114	06-11077A54	150
R115	06-11077A70	680
R116	06-11077A92	5.6k
R118	06-11077A70	680
R119	06-11077A88	3.9k
R120	06-11077A88	3.9k
R121	06-11077A84	2.7k
R122	06-11077A88	3.9k
R123	06-11077A74	1k
R124	06-11077A78	1.5k
R125	06-11077A44	56
R126	06-11077A50	100
R127	06-11077A84	2.7k
R128	06-11077A72	820
R151	06-11077B15	47k
R152	06-11077B11	33k
R153	06-11077B15	47k
R154	06-11077A34	22
R155	06-11077A98	10k
R156	06-11077B03	15k
R157	06-11077A78	1.5k
R158	06-11077A74	1k
R159	06-11077A74	1k
R161	06-11077A98	10k
R162		not used
R163(N)	06-11077B23	100k
R163(W)	06-11077B17	56k
R164	18-05500L08	variable 22k
R165(N)	06-11077A98	10k
R165(W)	06-11077B03	15k
R176	06-11077G26	22.6k 1%
R177	06-11077G18	18.7k 1%
R178	06-11077F91	10.0k 1%
R179	06-11077F91	10.0k 1%
R180	06-11077G52	42.2k 1%
R181	06-11077F91	10.0k 1%
R182	06-11077G28	23.7k 1%
R207	06-11077A44	56
R208	06-11077A44	56
R209	06-11077A38	33
R210	06-11077A98	10k
R212	06-11077A84	2.7k

R213	06-11077A72	820
R214	06-11077A50	100
R215	06-11077A84	2.7k
R216	06-11077A72	820
R217	06-11077A66	470
R218	06-11077A56	180
R219	06-11077A38	33
R220	06-11077A56	180
R222	06-11077A88	3.9k
R223	06-11077A94	6.8k
R224	06-11077B23	100k
R225	06-11077A90	4.7k
R226	06-11077A44	56
R227	06-11077A34	22
R228	06-11077A38	33
R229	06-11077A98	10k
R231	06-11077A84	2.7k
R232	06-11077A72	820
R233	06-11077A46	68
R234	06-11077A84	2.7k
R235	06-11077A72	820
R236	06-11077A46	68
R237	06-11077A66	470
R238	06-11077A28	12
R239	06-11077A66	470
R240		not used
R243	06-11077B23	100k
R244	06-11077A74	1k
R245	06-11077A74	1k
R246	06-11077B09	27k
R276	06-11077A98	10k
R277	06-11077A60	270
R278	06-11077A26	10
R279	06-11077A90	4.7k
R280	06-11077A98	10k
R281	06-11077A90	4.7k
R301(N)	06-11077B03	15k
R301(W)	06-11077A82	2.2k
R302	18-05500L08	variable 22k
R303	06-11077A94	6.8k

Transformers

T1	25-80163M02	balun
T2	25-80163M02	balun

Integrated circuits and modules (see note)

U1	48-80174R01	quad Schottky ring SOIC
U51	51-05479G05	receiver system
U101	51-84704M75	synthesizer
U102	51-83977M45	prescaler
U176	51-80932W01	dual op-amp

Voltage regulators (see note)

VR176	48-82256C11	zener diode 10V 5%
-------	-------------	--------------------

Crystals

Y51(N)	91-80022M03	filter 45.1 MHz 12.5 kHz
Y51(W)	91-80022M02	filter 45.1 MHz 25 kHz
Y52	48-80008K02	44.645 MHz
Y151	48-80174D05	14.4 MHz

Non-referenced items

26-80097M01	shield coil can (for L151)
26-80098M01	shield coil can (10 used)
26-80228L01	shield can (2 used, for J4 and J5)
26-80229L03	shield VCO frame
42-80957X01	ground clip
75-05295B02	insulator (for Y151)
75-05295B05	insulator (3 used, for Y51A/B, Y52)

Note: For optimum performance, diodes, transistors, and integrated circuits must be ordered by Motorola part numbers.

HLN8074A Logic Board 2-Layer Masked

REFERENCE NUMBER	MOTOROLA PART NO.	DESCRIPTION
------------------	-------------------	-------------

Capacitor, chip, 5%, 50V unless otherwise indicated.

C401	21-13741B45	.01 uF
C402	08-11051A09	poly .022 uF 63V
C403	21-13741B45	.01 uF
C404	23-11048B19	lytic 47 uF 20% 16V
C405	23-11048B13	lytic 10 uF 20% 16V
C406	08-11051A15	poly .22 uF 63V
C407	23-11013A56	tantalum 47 uF 20% 6V
C408	23-11048B19	lytic 47 uF 20% 16V
C409	08-11051A17	poly .47 uF 63V
C451	23-11048B19	lytic 47 uF 20% 16V
C452	21-13741B45	.01 uF
C453	21-11032B14	.15 uF +80/-20%
C454	21-13741B45	.01 uF
C455	08-11051A15	poly .22 uF 63V
C458	21-13740B36	30 pF
C459	21-13740B36	30 pF
C460	21-13741B45	.01 uF
C461	21-13741B45	.01 uF
C463	21-13740B36	30 pF
C464	21-13740B36	30 pF
C465	21-13740B36	30 pF
C466		not used
C501	08-11051A22	poly .039 uF 63V
C502	21-13740B76	1500 pF
C503	21-13741B69	.1 uF
C504	23-11048B13	lytic 10 uF 20% 16V
C505	08-11051A17	poly .47 uF 63V
C506	08-11051A17	poly .47 uF 63V
C507		not used
C551	23-11048B13	lytic 10 uF 20% 16V
C552	21-13740B36	30 pF
C553	21-13740B71	820 pF
C554	08-11051A03	poly .0022 uF 63V
C555	21-13740B51	120 pF
C556	08-11051A12	poly .068 uF 63V
C557	08-11051A12	poly .068 uF 63V
C558	08-11051A12	poly .068 uF 63V
C559	08-11051A13	poly .1 uF 63V
C560	08-11051A13	poly .1 uF 63V
C561	08-11051A15	poly .22 uF 63V
C562	08-11051A09	poly .022 uF 63V
C563	21-13741B69	.1 uF
C564	21-13740B49	100 pF
C565	23-11048B13	lytic 10 uF 20% 16V
C566	21-13741B45	.01 uF
C567	21-13741B45	.01 uF
C568	23-11048B19	lytic 47 uF 20% 16V
C601	23-11048B05	lytic 1 uF 20% 50V
C604		not used
C605		not used
C606	08-11051A22	poly .039 uF 63V
C607	08-11051A13	poly .1 uF 63V
C608	08-11051A05	poly .0047 uF 63V
C609	21-13740B60	300 pF
C610	08-11051A16	poly .33 uF 63V
C611	21-13740B49	100 pF
C612	23-11048B19	lytic 47 uF 20% 16V
C651	23-11048B19	lytic 47 uF 20% 16V
C652	08-11051A06	poly .0068 uF 63V
C653	08-11051A15	poly .22 uF 63V
C656	23-11048B13	lytic 10 uF 20% 16V
C657	21-13741B69	.1 uF
C658	21-13741B45	.01 uF
C659	23-11013A56	tantalum 47 uF 20% 6V
C660	23-11048B13	lytic 10 uF 20% 16V
C661	21-13740B74	1200 pF
C662	08-11051A07	poly .01 uF 63V
C663	21-13740B50	110 pF
C664	23-11048B09	lytic 4.7 uF 20% 35V
C665	21-13740B36	30 pF

C666	21-13740B74	1200 pF
C667	08-11051A08	poly .015 uF 63V
C668	08-11051A13	poly .1 uF 63V
C701	21-13740B78	1800 pF
C703	23-11048B05	lytic 1 uF 20% 50V
C704	08-11051A12	poly .068 uF 63V
C705	08-11051A16	poly .33 uF 63V
C706	08-11051A03	poly .0022 uF 63V
C707	21-13740B69	680 pF
C801	21-13740B49	100 pF
C802	21-13740B49	100 pF
C803		not used
C804		not used
C805	21-13740B73	1000 pF
C808	21-13740B49	100 pF
C809	21-13740B49	100 pF
C819	21-13740B73	1000 pF
C824	21-13740B49	100 pF
C827	23-11048B05	lytic 1 uF 20% 50V
C828	21-13741B69	.1 uF
C829	21-13741B45	.01 uF
C830	21-13740B31	18pF
C831	21-13740B21	6.8 +/- .25 pF
C832	21-13740B30	16 pF
C834	21-13741B69	.1 uF
C835	21-13741B69	.1 uF
C836	21-13740B73	1000 pF
C841	21-13740B73	1000 pF
C843	21-13740B73	1000 pF
C844	21-13740B73	1000 pF
C845	21-13740B73	1000 pF
C846	21-13740B73	1000 pF
C847	21-13740B73	1000 pF
C851	21-13740B73	1000 pF
C854	21-13740B73	1000 pF
C855	23-11013A56	tantalum 47 uF 20% 6V
C856	21-13740B49	100 pF
C857	21-13740B73	1000 pF
C858	21-13740B73	1000 pF
C869	21-13740B73	1000 pF
C870	21-13740B49	100 pF
C914		not used
C915		not used
C916		not used
C917		not used
C918		not used
C919		not used
C920		not used
C922		not used

Diodes (see note)

CR401	48-05129M76	silicon SOT
CR402	48-83654H02	silicon
CR403	48-05129M76	silicon SOT
CR451	48-05129M76	silicon SOT
CR551	48-05129M76	silicon SOT
CR603	48-84336R03	dual silicon SOT MMBD7000
CR651	48-05129M76	silicon SOT
CR801	48-05129M76	silicon SOT

Fuse

F801	65-05214E04	2 amp axial lead
------	-------------	------------------

Connector, receptacle

J3	28-80923V01	16-pin, accessories
J6	09-80130M03	14-pin, RF board
J7	28-80128M03	6 pin, RF power amplifier
J8	28-80600B01	27-pin, includes J8 and J9

Jumpers

JU551	09-80601B01	push-on jumper, 2-pin
JU601	09-80601B01	push-on jumper, 2-pin
JU651	09-80601B01	push-on jumper, 2-pin
JU809	09-80601B01	push-on jumper, 2-pin

Coils

L801	24-11087A42	chip 22 uH ferrite
L802	24-11087A42	chip 22 uH ferrite
L803	24-11087A42	chip 22 uH ferrite

Connector, Plug

P551	28-80002R03	3-pin header
P601	28-80002R03	3-pin header
P651	28-80002R03	3-pin header
P809	28-80002R03	3-pin header

Transistors (see note)

Q401	48-00869619	PNP, type M9619
Q402	48-80214G02	NPN; type MMBT3904
Q403	48-05128M67	PNP; type MMBT3906
Q404	48-80214G02	NPN; type MMBT3904
Q452	48-00869619	PNP, type M9619
Q453	48-80214G02	NPN; type MMBT3904
Q454	48-80214G02	NPN; type MMBT3904
Q455	48-80141L03	PNP, type M41L03
Q501	48-80214G02	NPN; type MMBT3904
Q551	48-80949V01	field effect; type MMBF5484
Q651	48-05128M67	PNP; type MMBT3906
Q652	48-80214G02	NPN; type MMBT3904
Q801	48-80214G02	NPN; type MMBT3904
Q802	48-80141L03	PNP, type M41L03
Q803	48-80947V01	digital NPN; type DTC144W
Q804	48-80214G02	NPN; type MMBT3904
Q805	48-80947V01	digital NPN; type DTC144W
Q806	48-80947V01	digital NPN; type DTC144W
Q807	48-80214G02	NPN; type MMBT3904
Q808	48-80214G02	NPN; type MMBT3904
Q809	48-80214G02	NPN; type MMBT3904
Q810	48-80214G02	NPN; type MMBT3904
Q811	48-80947V01	digital NPN; type DTC144W
Q812	48-80947V01	digital NPN; type DTC144W
Q821	48-80214G02	NPN; type MMBT3904

Resistors, chip, 5%, 1/10 watt, unless otherwise indicated.

R401	06-11077A70	680
R402	06-80195M37	330 1/2 watt
R403	06-11077A70	680
R404	06-11077F18	1.74k 1%
R405	06-11077F28	2.21k 1%
R406	06-11077A98	10k
R407	06-11077A76	1.2k
R408	06-11077F91	10.0k 1%
R409	06-11077F91	10.0k 1%
R410	06-11077A80	1.8k
R411	06-11077A78	1.5k
R412	06-11077A84	2.7k
R413	06-11077A98	10k
R414	06-11077A98	10k
R453	06-11077A70	680
R454	06-80195M37	330 1/2 watt
R455	06-11077A70	680
R456	06-11077A82	2.2k
R457	06-11077A76	1.2k
R458	06-11077A90	4.7k
R459	06-11077A90	4.7k
R460	06-11077B01	12k
R461	06-11077A70	680
R462	06-11077B29	180k
R463	06-11077B25	120k
R464	06-11077G88	100k 1%
R465	06-11077G88	100k 1%
R466	06-11077F91	10.0k 1%
R467	06-11077F91	10.0k 1%
R468	06-11077A60	270
R469	06-11077A74	1k
R470	06-11077A98	10k
R471	06-11077B07	22k
R472	06-11077A92	5.6k
R473	06-11077B09	27k

R474	06-11077A98	10k
R501	06-11077B23	100k
R502	06-11077A90	4.7k
R503	06-11077A78	1.5k
R551	06-11077A94	6.8k
R552	06-11077B37	390k
R553	06-11077B18	62k
R554	06-11077B18	62k
R555	06-11077B18	62k
R556	06-11077F53	4.02k 1%
R557	06-11077F20	1.82k 1%
R558	06-11077G42	33.2k 1%
R559	06-11077G88	100k 1%
R560	06-11077E77	665 1%
R561	06-11077G88	100k 1%
R562	06-11077B16	51k
R563	06-11077B15	47k
R567	06-11077A86	3.3k
R568	06-11077B07	22k
R569	06-11077A42	47
R570	06-11077B23	100k
R573	06-11077B09	27k
R574	06-11077A98	10k
R575	06-11077B10	30k
R576	06-11077B10	30k
R577	06-11077B23	100k
R578	06-11077A42	47
R581	06-11077A68	560
R601	06-11077A98	10k
R602	06-11077B47	1 meg
R603	06-11077A74	1k
R607		not used
R608		not used
R609	06-11077B11	33k
R610	06-11077B15	47k
R611	06-11077G42	33.2k 1%
R612	06-11077G42	33.2k 1%
R613	06-11077G42	33.2k 1%
R615	06-11077G95	118k 1%
R616	06-11077G31	25.5k 1%
R617	06-11077A82	2.2k
R620	06-11077A98	10k
R622	06-11077B31	220k
R651	06-11077A68	560
R652	06-11077A50	100
R653	06-11077A98	10k
R654	06-11077A98	10k
R655	06-11077A90	4.7k
R656	06-11077B39	470k
R657	06-11077B42	620k
R658	06-11077H65	619k 1%
R659	06-11077A82	2.2k
R660	06-11077B19	68k
R661	06-11077B03	15k
R662	06-11077B17	56k
R663	06-11077B18	62k
R664	06-11077B07	22k
R665	06-11077A84	2.7k
R666	06-11077B23	100k
R667	06-11077B23	100k
R668	06-11077G56	46.4k 1%
R669	06-11077G42	33.2k 1%
R670	06-11077G42	33.2k 1%
R671	06-11077A61	300
R672	06-11077B17	56k
R673	06-11077B23	100k
R674	06-11077A82	2.2k
R701	06-11077G88	100k 1%
R702	06-11077H13	178k 1%
R703	06-11077G31	25.5k 1%
R705	06-11077H13	178k 1%
R706	06-11077G56	46.4k 1%
R707	06-11077G95	118k 1%
R708	06-11077B15	47k
R709	06-11077B19	68k
R710	06-11077G13	16.5k 1%
R711	06-11077G13	16.5k 1%
R714	06-11077B10	30k

R715	06-11077B05	18k
R716	06-11077A86	3.3k
R801	06-11077A78	1.5k
R802	06-11077A84	2.7k
R803	06-11077A98	10k
R804	06-11077A90	4.7k
R807	06-11077B15	47k
R808	06-11077A90	4.7k
R809	06-11077A90	4.7k
R810	06-11077B17	56k
R811	06-11077B17	56k
R812	06-11077A90	4.7k
R813	06-11077A90	4.7k
R814	06-11077A90	4.7k
R815	06-11077A90	4.7k
R816	06-11077B23	100k
R817	06-11077B23	100k
R818	06-11077B23	100k
R822	06-11077B15	47k
R825	06-11077B15	47k
R826	06-11077A90	4.7k
R827	06-11077A98	10k
R828	06-11077A98	10k
R831	06-11077A74	1k
R832	06-11077A74	1k
R833	06-11077A98	10k
R836	06-11077A98	10k
R842	06-11077A74	1k
R845	06-11077A74	1k
R846	06-11077A98	10k
R847	06-11077A74	1k
R849	06-11077A98	10k
R850	06-11077A74	1k
R851	06-11077B15	47k
R852	06-11077B15	47k
R853	06-11077B45	820k
R854	06-11077A90	4.7k
R857	06-11077A98	10k
R858	06-11077A98	10k
R859	06-11077A98	10k
R860	06-11077A98	10k
R862	06-11077F95	11.0k 1%
R863	06-11077F91	10.0k 1%
R864	06-11077F20	1.82k 1%
R865	06-11077A98	10k
R866	06-11077A98	10k
R867	06-11077A98	10k
R868	06-11077A98	10k
R869	06-11077A98	10k
R870	06-11077A98	10k
R871	06-11077A98	10k
R872	06-11077A98	10k
R876	06-11077A98	10k
R877	06-11077B23	100k
R878	06-11077B23	100k
R879	06-11077B23	100k
R880	06-11077B15	47k
R883	06-11077A90	4.7k
R884	06-11077B15	47k
R887	06-11077A90	4.7k
R889	06-11077A68	560
R890	06-11077A98	10k
R918	06-11077A98	10k
R919	06-11077A98	10k

Integrated circuits and modules (see note)

U401	51-02198J22	dual op-amp 4558 SOIC
U402	51-80942T01	regulator, 5V with reset
U451	51-02198J22	dual op-amp 4558 SOIC
U501	51-80147R01	audio power amp TDA1519A
U551	51-02198J22	dual op-amp 4558 SOIC
U552	51-02198J22	dual op-amp 4558 SOIC
U553	51-02198J22	dual op-amp 4558 SOIC
U601	51-02198J23	dual comparator 2903 SOIC
U602	51-02198J22	dual op-amp 4558 SOIC
U603	51-02198J22	dual op-amp 4558 SOIC
U651	51-02198J22	dual op-amp 4558 SOIC

U652	51-02198J22	dual op-amp 4558 SOIC
U653	51-80059M01	voltage-controlled attenuator
U801	51-80135C10	D/A converter MC144110
U802	51-80649B01	microcomputer MC68HC11E9

Voltage regulators (see note)

VR401	48-83461E40	zener diode 5.1V 1%
VR402	48-80140L06	zener diode 5.1V SOT
VR551	48-80140L15	zener diode 10V SOT
VR552	48-80140L15	zener diode 10V SOT
VR801	48-80948V01	zener diode 27V SOT
VR802	48-80948V01	zener diode 27V SOT
VR803		not used
VR804		not used
VR805		not used
VR807		not used
VR811	48-80948V01	zener diode 27V SOT
VR812	48-82256C20	zener diode 27V
VR813	48-80948V01	zener diode 27V SOT
VR814	48-80948V01	zener diode 27V SOT

Crystals

Y801	48-80173D09	7.776 MHz
------	-------------	-----------

Non-referenced items

03-10943M04	screw M2.5 X 8 (2 used, for Q401 and Q452)
03-80271L01	screw (2 used for U501)
04-00136334	washer flat (2 used for U501)
14-83820M05	insulator (2 used, for Q401 and Q452)
26-80497B01	heatsink
01-80701Y58	connector assembly (mates with J3)
09-82071K09	14 pin socket (2 used for U804)
26-80123M02	logic shield frame

Note: For optimum performance, diodes, transistors, and integrated circuits must be ordered by Motorola part numbers.

3/13/92

PL-92011-O

HLN8070A Logic Board 4-Layer Expanded

REFERENCE NUMBER	MOTOROLA PART NO.	DESCRIPTION
------------------	-------------------	-------------

Capacitor, chip, 5%, 50V unless otherwise indicated.

C401	21-13741B45	.01 uF
C402	08-11051A09	poly .022 uF 63V
C403	21-13741B45	.01 uF
C404	23-11048B19	lytic 47 uF 20% 16V
C405	23-11048B13	lytic 10 uF 20% 16V
C406	08-11051A15	poly .22 uF 63V
C407	23-11013A56	tantalum 47 uF 20% 6V
C408	23-11048B19	lytic 47 uF 20% 16V
C409	08-11051A17	poly .47 uF 63V
C451	23-11048B19	lytic 47 uF 20% 16V
C452	21-13741B45	.01 uF
C453	21-11032B14	.15 uF +80/-20%
C454	21-13741B45	.01 uF
C455	08-11051A15	poly .22 uF 63V
C458	21-13740B36	30 pF
C459	21-13740B36	30 pF
C460	21-13741B45	.01 uF
C461	21-13741B45	.01 uF
C462	21-11032B15	.22 uF +80/-20%
C463	21-13740B36	30 pF
C464	21-13740B36	30 pF
C465	21-13740B36	30 pF
C466		not used
C501	08-11051A22	poly .039 uF 63V
C502	21-13740B76	1500 pF
C503	21-13741B69	.1 uF
C504	23-11048B13	lytic 10 uF 20% 16V
C505	08-11051A17	poly .47 uF 63V
C507		not used
C551	23-11048B13	lytic 10 uF 20% 16V
C552	21-13740B36	30 pF
C553	21-13740B71	820 pF
C554	08-11051A03	poly .0022 uF 63V
C555	21-13740B51	120 pF
C556	08-11051A12	poly .068 uF 63V
C557	08-11051A12	poly .068 uF 63V
C558	08-11051A12	poly .068 uF 63V
C559	08-11051A13	poly .1 uF 63V
C560	08-11051A13	poly .1 uF 63V
C561	08-11051A15	poly .22 uF 63V
C562	08-11051A09	poly .022 uF 63V
C563	21-13741B69	.1 uF
C564	21-13740B49	100 pF
C565	23-11048B13	lytic 10 uF 20% 16V
C566	21-13741B45	.01 uF
C567	21-13741B45	.01 uF
C568	23-11048B19	lytic 47 uF 20% 16V
C569	21-13740B33	22 pF
C601	23-11048B05	lytic 1 uF 20% 50V
C604		not used
C605		not used
C606	08-11051A22	poly .039 uF 63V
C607	08-11051A13	poly .1 uF 63V
C608	08-11051A05	poly .0047 uF 63V
C609	21-13740B60	300 pF
C610	08-11051A16	poly .33 uF 63V
C611	21-13740B49	100 pF
C612	23-11048B19	lytic 47 uF 20% 16V
C651	23-11048B19	lytic 47 uF 20% 16V
C652	08-11051A06	poly .0068 uF 63V
C653	08-11051A15	poly .22 uF 63V
C656	23-11048B13	lytic 10 uF 20% 16V
C657	21-13741B69	.1 uF
C658	21-13741B45	.01 uF
C659	23-11013A56	tantalum 47 uF 20% 6V
C660	23-11048B13	lytic 10 uF 20% 16V
C661	21-13740B74	1200 pF
C662	08-11051A07	poly .01 uF 63V
C663	21-13740B50	110 pF
C664	23-11048B09	lytic 4.7 uF 20% 35V

C665	21-13740B36	30 pF
C666	21-13740B74	1200 pF
C667	08-11051A08	poly .015 uF 63V
C668	08-11051A13	poly .1 uF 63V
C701	21-13740B78	1800 pF
C703	23-11048B05	lytic 1 uF 20% 50V
C704	08-11051A12	poly .068 uF 63V
C705	08-11051A16	poly .33 uF 63V
C706	08-11051A03	poly .0022 uF 63V
C707	21-13740B69	680 pF
C801	21-13740B49	100 pF
C802	21-13740B49	100 pF
C803	21-13740B73	1000 pF
C804	21-13740B73	1000 pF
C805	21-13740B73	1000 pF
C806	21-13740B73	1000 pF
C807	21-13740B73	1000 pF
C808	21-13740B49	100 pF
C809	21-13740B49	100 pF
C810	21-13740B73	1000 pF
C811	21-13740B73	1000 pF
C812	21-13740B73	1000 pF
C813	21-13740B73	1000 pF
C814	21-13740B73	1000 pF
C815	21-13740B73	1000 pF
C816	21-13740B73	1000 pF
C817	21-13740B73	1000 pF
C818	21-13740B73	1000 pF
C819	21-13740B73	1000 pF
C820	21-13740B73	1000 pF
C821	21-13740B73	1000 pF
C822	21-13740B73	1000 pF
C823	21-13740B73	1000 pF
C824	21-13740B49	100 pF
C825	21-13740B49	100 pF
C826	21-13740B73	1000 pF
C827	23-11048B05	lytic 1 uF 20% 50V
C828	21-13741B69	.1 uF
C829	21-13741B45	.01 uF
C830	21-13740B25	10 pF
C831	21-13740B19	5.6 +/- .25 pF
C832	21-13740B25	10 pF
C833	21-13740B73	1000 pF
C834	21-13741B69	.1 uF
C835	21-13741B69	.1 uF
C836	21-13740B73	1000 pF
C837	21-13741B45	.01 uF
C838	21-13741B45	.01 uF
C839	21-13741B45	.01 uF
C840	21-13741B45	.01 uF
C841	21-13740B73	1000 pF
C842	21-13740B73	1000 pF
C843	21-13740B73	1000 pF
C844	21-13740B73	1000 pF
C845	21-13740B73	1000 pF
C846	21-13740B73	1000 pF
C847	21-13740B73	1000 pF
C848	21-13740B73	1000 pF
C849	21-13740B49	100 pF
C850	21-13740B73	1000 pF
C851		not used
C852	21-13741B45	.01 uF
C853	21-13741B45	.01 uF
C854	21-13740B73	1000 pF
C855	23-11013A56	tantalum 47 uF 20% 6V
C856	21-13740B49	100 pF
C857	21-13740B73	1000 pF
C858	21-13740B73	1000 pF
C860	21-13741B53	.022 uF
C861	21-13740B73	1000 pF
C862	21-13741B53	.022 uF
C863	21-13740B73	1000 pF
C864	21-13740B49	100 pF
C865	21-13740B73	1000 pF
C866	21-13740B49	100 pF
C867	21-13740B73	1000 pF
C868	21-13740B73	1000 pF
C869	21-13740B73	1000 pF

Diodes (see note)

CR401	48-05129M76	silicon SOT
CR402	48-83654H02	silicon
CR403	48-05129M76	silicon SOT
CR451	48-05129M76	silicon SOT
CR551	48-05129M76	silicon SOT
CR603	48-84336R03	dual silicon SOT MMBD7000
CR651	48-05129M76	silicon SOT

Fuse

F801	65-05214E04	2 amp axial lead
------	-------------	------------------

Connector, receptacle

J3	28-80923V01	16-pin, accessories
J6	09-80130M03	14-pin, RF board
J7	28-80128M03	6 pin, RF power amplifier
J8/J9	28-80600B01	27-pin, includes J8 and J9

Jumpers

JU551	09-80601B01	push-on jumper, 2-pin
JU601	09-80601B01	push-on jumper, 2-pin
JU651	09-80601B01	push-on jumper, 2-pin
JU802	06-11077A01	jumper
JU803		not used
JU804	06-11077A01	jumper
JU805		not used
JU806	06-11077A01	jumper
JU807	06-11009B23	jumper
JU808	09-80601B01	push-on jumper, 2-pin

Coils

L801	24-11087A42	chip 22 uH ferrite
L802	24-83961B02	5 turns GRN
L803	24-83961B02	5 turns GRN

Connector, Plug

P551	28-80002R03	3-pin header
P601	28-80002R03	3-pin header
P651	28-80002R03	3-pin header
P808	28-80002R03	3-pin header

Transistors (see note)

Q401	48-00869619	PNP, type M9619
Q402	48-80214G02	NPN; type MMBT3904
Q403	48-05128M67	PNP; type MMBT3906
Q404	48-80214G02	NPN; type MMBT3904
Q452	48-00869619	PNP, type M9619
Q453	48-80214G02	NPN; type MMBT3904
Q454	48-80214G02	NPN; type MMBT3904
Q455	48-80141L03	PNP, type M41L03
Q456	48-80214G02	NPN; type MMBT3904
Q501	48-80214G02	NPN; type MMBT3904
Q551	48-80949V01	field effect; type MMBF5484
Q601	48-80214G02	NPN; type MMBT3904
Q651	48-05128M67	PNP; type MMBT3906
Q652	48-80214G02	NPN; type MMBT3904
Q801	48-80214G02	NPN; type MMBT3904
Q802	48-80141L03	PNP, type M41L03
Q803	48-80947V01	digital NPN; type DTC144W
Q804	48-80214G02	NPN; type MMBT3904
Q805	48-80947V01	digital NPN; type DTC144W
Q806	48-80947V01	digital NPN; type DTC144W
Q807	48-80214G02	NPN; type MMBT3904
Q808	48-05128M67	PNP; type MMBT3906
Q809	48-05128M67	PNP; type MMBT3906
Q810	48-80214G02	NPN; type MMBT3904
Q811	48-80947V01	digital NPN; type DTC144W
Q812	48-80947V01	digital NPN; type DTC144W
Q813	48-80947V01	digital NPN; type DTC144W
Q814	48-80214G02	NPN; type MMBT3904
Q815	48-80947V01	digital NPN; type DTC144W

Q816	48-80214G02	NPN; type MMBT3904
Q817	48-80947V01	digital NPN; type DTC144W
Q818	48-80214G02	NPN; type MMBT3904
Q819	48-80214G02	NPN; type MMBT3904
Q820	48-80947V01	digital NPN; type DTC144W

Resistors, chip, 5%, 1/10 watt, unless otherwise indicated.

R401	06-11077A70	680
R402	06-80195M37	330 1/2 watt
R403	06-11077A70	680
R404	06-11077F18	1.74k 1%
R405	06-11077F28	2.21k 1%
R406	06-11077A98	10k
R407	06-11077A76	1.2k
R408	06-11077F91	10.0k 1%
R409	06-11077F91	10.0k 1%
R410	06-11077A80	1.8k
R411	06-11077A78	1.5k
R412	06-11077A84	2.7k
R413	06-11077A98	10k
R414	06-11077A98	10k
R453	06-11077A70	680
R454	06-80195M37	330 1/2 watt
R455	06-11077A70	680
R456	06-11077A82	2.2k
R457	06-11077A76	1.2k
R458	06-11077A90	4.7k
R459	06-11077A90	4.7k
R460	06-11077B01	12k
R461	06-11077A70	680
R462	06-11077B29	180k
R463	06-11077B25	120k
R464	06-11077G88	100k 1%
R465	06-11077G88	100k 1%
R466	06-11077F91	10.0k 1%
R467	06-11077F91	10.0k 1%
R468	06-11077A60	270
R469	06-11077A74	1k
R470	06-11077A98	10k
R471	06-11077B07	22k
R472	06-11077A92	5.6k
R473	06-11077B09	27k
R474	06-11077A98	10k
R475	06-11077G88	100k 1%
R476	06-11077G57	47.5k 1%
R477	06-11077A90	4.7k
R501	06-11077B23	100k
R502	06-11077A90	4.7k
R503	06-11077A78	1.5k
R551	06-11077A94	6.8k
R552	06-11077B37	390k
R553	06-11077B18	62k
R554	06-11077B18	62k
R555	06-11077B18	62k
R556	06-11077F53	4.02k 1%
R557	06-11077F20	1.82k 1%
R558	06-11077G42	33.2k 1%
R559	06-11077G88	100k 1%
R560	06-11077E77	665 1%
R561	06-11077G88	100k 1%
R562	06-11077B16	51k
R563	06-11077B15	47k
R567	06-11077A86	3.3k
R568	06-11077B07	22k
R569	06-11077A42	47
R570	06-11077B23	100k
R573	06-11077B09	27k
R574	06-11077A98	10k
R575	06-11077B10	30k
R576	06-11077B10	30k
R577	06-11077B23	100k
R578	06-11077A42	47
R579	06-11077B37	390k
R580	06-11077B09	27k
R581	06-11077A68	560
R601	06-11077A98	10k
R602	06-11077B47	1 meg

R603	06-11077A74	1k
R607		not used
R608		not used
R609	06-11077B11	33k
R610	06-11077B15	47k
R611	06-11077G42	33.2k 1%
R612	06-11077G42	33.2k 1%
R613	06-11077G42	33.2k 1%
R615	06-11077G95	118k 1%
R616	06-11077G31	25.5k 1%
R617	06-11077A82	2.2k
R618	06-11077B23	100k
R619	06-11077A98	10k
R620	06-11077A98	10k
R622	06-11077B31	220k
R651	06-11077A68	560
R652	06-11077A50	100
R653	06-11077A98	10k
R654	06-11077A98	10k
R655	06-11077A90	4.7k
R656	06-11077B39	470k
R657	06-11077B42	620k
R658	06-11077H65	619k 1%
R659	06-11077A82	2.2k
R660	06-11077B19	68k
R661	06-11077B03	15k
R662	06-11077B17	56k
R663	06-11077B18	62k
R664	06-11077B07	22k
R665	06-11077A84	2.7k
R666	06-11077B23	100k
R667	06-11077B23	100k
R668	06-11077G56	46.4k 1%
R669	06-11077G42	33.2k 1%
R670	06-11077G42	33.2k 1%
R671	06-11077A61	300
R672	06-11077B17	56k
R673	06-11077B23	100k
R674	06-11077A82	2.2k
R701	06-11077G88	100k 1%
R702	06-11077H13	178k 1%
R703	06-11077G31	25.5k 1%
R705	06-11077H13	178k 1%
R706	06-11077G56	46.4k 1%
R707	06-11077G95	118k 1%
R708	06-11077B15	47k
R709	06-11077B19	68k
R710	06-11077G13	16.5k 1%
R711	06-11077G13	16.5k 1%
R714	06-11077B10	30k
R715	06-11077B05	18k
R716	06-11077A86	3.3k
R801	06-11077A78	1.5k
R802	06-11077A84	2.7k
R803	06-11077A98	10k
R804	06-11077A90	4.7k
R807	06-11077B15	47k
R808	06-11077A90	4.7k
R809	06-11077A90	4.7k
R810	06-11077B17	56k
R811	06-11077B17	56k
R812	06-11077A90	4.7k
R813	06-11077A90	4.7k
R814	06-11077A90	4.7k
R815	06-11077A90	4.7k
R816	06-11077B23	100k
R817	06-11077B23	100k
R818	06-11077B23	100k
R822	06-11077B15	47k
R825	06-11077B15	47k
R826	06-11077A90	4.7k
R827	06-11077A98	10k
R828	06-11077A98	10k
R829	06-11077A74	1k
R830	06-11077A74	1k
R831	06-11077A50	100
R832	06-11077A50	100
R833	06-11077A98	10k

R834	06-11077F91	10.0k 1%
R835	06-11077B05	18k
R836	06-11077A98	10k
R837	06-11077B05	18k
R838	06-11077F91	10.0k 1%
R839	06-11077A98	10k
R840	06-11077A98	10k
R841	06-11077A98	10k
R842	06-11077A74	1k
R843	06-11077A98	10k
R844	06-11077A98	10k
R845	06-11077A74	1k
R846	06-11077A98	10k
R847	06-11077A50	100
R848	06-11077A74	1k
R849	06-11077A98	10k
R850	06-11077A74	1k
R851	06-11077B15	47k
R852	06-11077B15	47k
R853	06-11077B45	820k
R854	06-11077A90	4.7k
R855	06-11077B15	47k
R856	06-11077A74	1k
R857	06-11077A98	10k
R858	06-11077A98	10k
R859	06-11077A98	10k
R860	06-11077A98	10k
R861	06-11077B23	100k
R862	06-11077F95	11.0k 1%
R863	06-11077F91	10.0k 1%
R864	06-11077F20	1.82k 1%
R865	06-11077A98	10k
R866	06-11077A98	10k
R867	06-11077A98	10k
R868	06-11077A98	10k
R869	06-11077A98	10k
R870	06-11077A98	10k
R871	06-11077A98	10k
R872	06-11077A98	10k
R873	06-11077A98	10k
R874	06-11077A74	1k
R875	06-11077A98	10k
R876	06-11077A98	10k
R877	06-11077B23	100k
R878	06-11077B23	100k
R879	06-11077B23	100k
R880	06-11077B15	47k
R883	06-11077A90	4.7k
R884	06-11077B15	47k
R887	06-11077A90	4.7k
R888		not used
R889	06-11077A68	560
R890	06-11077A98	10k
R899	06-11077A98	10k
R901	06-11077A90	4.7k
R902	06-11077B15	47k
R903	06-11077A98	10k
R904	06-11077A98	10k
R905	06-11077A90	4.7k
R906	06-11077B15	47k
R907	06-11077A98	10k
R908	06-11077A98	10k
R909	06-11077A90	4.7k
R910	06-11077B15	47k
R911	06-11077A98	10k
R912	06-11077A98	10k
R913	06-11077A98	10k
R914	06-11077A90	4.7k
R915	06-11077B15	47k
R916	06-11077A98	10k
R917	06-11077A74	1k
R918	06-11077A98	10k

Integrated circuits and modules (see note)

U401	51-02198J22	dual op-amp 4558 SOIC
U402	51-80942T01	regulator, 5V with reset
U451	51-02198J22	dual op-amp 4558 SOIC

U501	51-80147R01	audio power amp TDA1519A
U551	51-02198J22	dual op-amp 4558 SOIC
U552	51-02198J22	dual op-amp 4558 SOIC
U553	51-02198J22	dual op-amp 4558 SOIC
U601	51-02198J23	dual comparator 2903 SOIC
U602	51-02198J22	dual op-amp 4558 SOIC
U603	51-02198J22	dual op-amp 4558 SOIC
U651	51-02198J22	dual op-amp 4558 SOIC
U652	51-02198J22	dual op-amp 4558 SOIC
U653	51-80059M01	voltage-controlled attenuator
U701	51-02198J22	dual op-amp 4558 SOIC
U801	51-80135C10	D/A converter MC144110
U802	51-80960T01	microcomputer
U803	51-82862N09	gate array
U804	HLN8121A	ROM kit
U805	51-80901W01	EEPROM
U806	51-80914V01	static RAM

Voltage regulators (see note)

VR401	48-83461E40	zener diode 5.1V 1%
VR402	48-80140L06	zener diode 5.1V
VR551	48-80140L15	zener diode 10V SOT
VR552	48-80140L15	zener diode 10V SOT
VR801	48-80948V01	zener diode 27V SOT
VR802	48-80948V01	zener diode 27V SOT
VR803		not used
VR804	48-80948V01	zener diode 27V SOT
VR805		not used
VR806		not used
VR807		not used
VR808	48-80948V01	zener diode 27V SOT
VR809	48-80948V01	zener diode 27V SOT
VR810	48-80948V01	zener diode 27V SOT
VR811	48-80948V01	zener diode 27V SOT
VR812	48-82256C20	zener diode 27V

Crystals

Y801	48-80173D09	7.776 MHz
------	-------------	-----------

Non-referenced items

03-10943M04	screw M2.5 X 8 (2 used, for Q401 and Q452)
03-80271L01	screw (2 used for U501)
04-00136334	washer flat (2 used for U501)
14-83820M05	insulator (2 used, for Q401 and Q452)
26-80497B01	heatsink
01-80701Y58	connector assembly (mates with J3)
09-82071K09	14 pin socket (2 used for U804)
26-80123M02	logic shield frame

Note: For optimum performance, diodes, transistors, and integrated circuits must be ordered by Motorola part numbers.

3/11/92

PL-921012-O

HLD8033A PA Board, 146-174 MHz, 10-25 Watt

REFERENCE NUMBER	MOTOROLA PART NO.	DESCRIPTION
------------------	-------------------	-------------

Capacitor, chip, 5%, 50V unless otherwise indicated.

C2307		not used
C2308		not used
C2309		not used
C2310	21-13740B65	470 pF
C2311	21-13740B37	33 pF
C2312	21-13740B65	470 pF
C2313	21-13740B65	470 pF
C2314	21-13741B69	.1 uF
C2315	21-13740B51	120 pF
C2316	21-13740B65	470 pF
C2317	21-13740B39	39 pF
C2318	21-13740B49	100 pF
C2319	21-13740B73	1000 pF
C2320	21-13740B65	470 pF
C2321	21-11032B15	.22 uF +80/-20%
C2322	21-13741B69	.1 uF
C2323	21-13740B65	470 pF
C2324	21-13740B29	15 pF
C2325	21-13740B27	12 pF
C2326	21-13740B31	18 pF
C2327	21-13740B65	470 pF
C2330	21-13740B41	47 pF
C2331		not used
C2332		not used
C2334	21-80060M47	150 pF 100V
C2336	21-80060M39	68 pF 500V
C2337	21-80060M39	68 pF 500V
C2338	21-80060M29	27 pF 500V
C2339	21-11032B15	.22 uF +80/-20%
C2340	21-80060M11	6 pF 500V
C2342	21-13740B65	470 pF
C2343	21-80060M41	82 pF 500V
C2351	21-13740B19	5.6 +/- .25 pF
C2352	21-13740B53	150 pF
C2353	21-13740B36	30 pF
C2354	21-13740B65	470 pF
C2360	21-80060M30	30 pF 500V
C2361	21-80060M30	30 pF 500V
C2362	21-80060M29	27 pF 500V
C2363	21-80060M30	30 pF 500V
C2364	21-80060M27	22 pF 500V
C2365	21-13740B73	1000 pF
C2370	21-13740B65	470 pF
C2371	21-13741B69	.1 uF
C2372	21-13740B51	120 pF
C2373	21-13740B65	470 pF
C2374	21-13740B65	470 pF
C2375	21-13740B65	470 pF
C2376	21-13741B69	.1 uF
C2378	08-11051A17	poly .47 uF 63V
C2379	21-13740B65	470 pF
C2380	21-13740B65	470 pF

Diodes (see note)

CR2350	48-80010E01	silicon PIN
CR2351	48-80010E01	silicon PIN
CR2370	48-80236E07	transient suppressor diode

Ferrite Beads

E2370	76-83960B01	ferrite bead 1/2 turn
-------	-------------	-----------------------

Coils

L2310	24-11030A03	4 turns YEL
L2311	24-11030B07	3-1/2 turns WHT
L2312	24-11030E01	1/2 turn BRN
L2313	24-11030B15	10-1/2 turns WHT
L2321	24-80036A01	ferrite bead 1/2 turn
L2322	24-11030B07	3-1/2 turns WHT

L2323	24-80036A01	ferrite bead 1/2 turn
L2324	24-82723H46	.2 uH
L2325	24-11030B06	2-1/2 turns BLU
L2330	24-11030A01	2 turns RED
L2331	24-11030E01	1/2 turn BRN
L2332	24-80036A01	ferrite bead 1/2 turn
L2333	24-11030B15	10-1/2 turns WHT
L2334	24-11030E04	1/2 turn YEL
L2335	24-11030A02	3 turns ORG
L2336	24-11030A03	4 turns YEL
L2350	24-82723H49	1.2 uH
L2351	24-11030B10	5-1/2 turns RED
L2352	24-82723H44	.039 uH
L2353	24-82723H49	1.2 uH
L2360	24-11030B10	5-1/2 turns RED
L2361	24-11030B12	7-1/2 turns YEL
L2362	24-11030B12	7-1/2 turns YEL
L2363	24-11030B11	6-1/2 turns ORG
L2364	24-11030B15	10-1/2 turns WHT
L2370	24-84346A02	.23 uH

Transistors (see note)

Q2310	48-82233P39	NPN; type 33P39
Q2320	48-80225C23	NPN; type MRF237

Resistors, chip, 5%, 1/10 watt, unless otherwise indicated.

R2310	06-11077A46	68
R2311	06-11077A58	220
R2312	06-11077A60	270
R2313	06-11077A26	10
R2314	06-11077A26	10
R2320	06-11077A34	22
R2321	06-11077A50	100
R2329	06-11077A40	39
R2330	06-11077A40	39
R2331	06-80279M01	metal film 82 3 watt
R2332		not used
R2350	06-11009A39	390 1/4 watt
R2351	06-11077A66	470
R2352	06-11077A66	470
R2353	06-11077A50	100
R2370	06-11077A38	33
R2371	06-80147M01	metal plate .05 2 watt
R2372	06-05621T02	thermistor 50k
R2373	06-11077B11	33k
R2374	06-11077A74	1k

Non-referenced items

26-80158L01	heat sink (for Q2320)
29-80014A03	clip coax terminal (2 used)

Note: For optimum performance, diodes, transistors, and integrated circuits must be ordered by Motorola part numbers.

3/11/92

PL-921015-O

01-80704Y64 Feedthru Bracket and Cable Assembly

REFERENCE NUMBER	MOTOROLA PART NO.	DESCRIPTION
Non-referenced items		
	01-80556B01	6-wire cable assembly (includes P7)
	01-80634B01	feedthru bracket assembly (includes C2301 through C2306, 470 pF feedthru capacitors, 6 used)

HLN8069A PA Hardware Kit, VHF 25 Watt

REFERENCE NUMBER	MOTOROLA PART NO.	DESCRIPTION
Capacitors, chip		
C2329		not used
C2333	21-11078B52	240 pF 100V
C2335	21-11078B27	30 pF 100V
Connector, receptacle		
J1	09-80131M01	mini UHF coax
J2	09-80255E01	power (includes feedthru)
Connector, plug		
P4	30-80138M07	coaxial cable 158 mm with plug
P5	30-80138M08	coaxial cable 105 mm with plug
Transistors		
Q2330	48-80225C22	NPN; type MRF1946
Non-referenced items		
	02-00007003	nut 8-32x5/16x1/8 (for J1)
	03-10943M10	screw M3x.5x8 (8 used)
	03-10943M11	screw M3x.5x10 (2 used for J2)
	04-00131974	washer (2 used for J2)
	04-05587G01	washer nylon (for J2)
	04-80943V01	lockwasher (for J1)
	26-80124L01	heat sink
	26-80223M07	PA shield
	32-80014N03	gasket, accessory connector
	38-80014N01	plug button
	42-80281L01	ground clip (2 used for Q2330)
	42-80520B01	ground clip, pc board (2 used)

Note: For optimum performance, diodes, transistors, and integrated circuits must be ordered by Motorola part numbers.

3/11/92

PL-921016-O

HLE8034A PA Board, 449-470 MHz, 10-25 Watt

REFERENCE NUMBER	MOTOROLA PART NO.	DESCRIPTION
------------------	-------------------	-------------

Capacitor, chip, 5%, 50V unless otherwise indicated.

C2610	21-13740B49	100 pF
C2611	21-13740B27	12 pF
C2612	21-13740B29	15 pF
C2613	21-13740B73	1000 pF
C2614	21-13740B73	1000 pF
C2615	21-13740B21	6.8 +/- .25 pF
C2616	21-13741B69	.1 uF
C2617	21-13740B36	30 pF
C2618	21-13740B49	100 pF
C2619		not used
C2620	21-13740B31	18 pF
C2621	21-13740B34	24 pF
C2622		not used
C2623		not used
C2626	21-13740B49	100 pF
C2627	21-13740B73	1000 pF
C2628	21-11032B15	.22 uF +80/-20%
C2629	21-13740B36	30 pF
C2630	21-13740B37	33 pF
C2631	21-11078B23	24 pF 100V
C2632	21-11078B23	24 pF 100V
C2636	21-13740B49	100 pF
C2637	21-13740B73	1000 pF
C2638	21-13741B69	.1 uF
C2639	08-11051A17	poly .47 uF 63V
C2640	21-80060M33	39 pF 500V
C2645	21-80060M25	18 pF 500V
C2646	21-80060M19	10 pF 500V
C2647	21-80060M31	33 pF 500V
C2648	21-11032B15	.22 uF +80/-20%
C2649	21-13740B49	100 pF
C2650	21-80060M20	11 pF 500V
C2651	21-13740B09	2.2 +/- .25 pF
C2652	21-13740B17	4.7 +/- .25 pF
C2653	21-13740B49	100 pF
C2654	21-13740B49	100 pF
C2655	21-13740B49	100 pF
C2660	21-80060M17	9 +/- .5 pF 500V
C2661	21-80060M19	10 pF 500V
C2662	21-80060M17	9 +/- .5 pF 500V
C2663	21-80060M11	6 +/- .5 pF 500V
C2664	21-80060M43	100 pF 500V
C2670	21-13740B36	30 pF
C2671	21-13740B36	30 pF
C2672	21-13740B73	1000 pF
C2673	21-13741B69	.1 uF
C2674	21-13740B36	30 pF
C2675	08-11051A17	.47 uF 63V
C2676	21-13740B36	30 pF
C2677	21-13740B73	1000 pF
C2678	21-13741B69	.1 uF
C2679	21-13740B36	30 pF
C2680	21-13740B36	30 pF

Diodes (see note)

CR2650	48-80010E01	silicon PIN
CR2651	48-80010E01	silicon PIN
CR2670	48-80236E07	transient suppressor diode

Ferrite Beads

E2620	76-83960B01	ferrite bead 1/2 turn
E2670	76-83960B01	ferrite bead 1/2 turn
E2671	76-83960B01	ferrite bead 1/2 turn

Coils

L2610	24-11030E01	1/2 turn BRN
L2611	24-11030B04	1-1/2 turns YEL
L2612	24-11030E03	1/2 turn ORN

L2613	24-11030B01	1-1/2 turns BRN
L2614	24-80036A01	ferrite bead 1/2 turn
L2620	24-11030E01	1/2 turn BRN
L2621		not used
L2622	24-82723H44	.039 uH
L2630	24-11030A03	4 turns YEL
L2631	24-80036A01	ferrite bead 1/2 turn
L2632	24-80030A06	7 turns VIO
L2640	24-80036A01	ferrite bead 1/2 turn
L2641	24-11030A03	4 turns YEL
L2642	24-11030A02	3 turns ORG
L2643	24-11030E05	1/2 turn GRN
L2650	24-82723H40	.29 uH
L2651	24-11030B05	2 1/2 turns GRN
L2652	24-82723H40	.29 uH
L2653	24-11030B11	6-1/2 turns ORN
L2660	24-11030B04	1-1/2 turns YEL
L2661	24-11030B06	2-1/2 turns BLU
L2662	24-11030B06	2-1/2 turns BLU
L2663	24-11030B11	6-1/2 turns ORN
L2670	24-82723H46	.2 uH
L2671	24-84346A02	.23 uH

Connector, Plug

P4	29-80014A03	clip coax terminal
P5	29-80014A03	clip coax terminal
P7	07-80521B01	bracket, feedthru

Transistors (see note)

Q2610	48-82233P39	NPN; type 33P39
Q2620	48-80225C09	NPN; type 2509

Resistors, chip, 5%, 1/10 watt, unless otherwise indicated.

R2610	06-11077A60	270
R2611	06-11077A58	220
R2612	06-11077A52	120
R2613	06-11077A40	39
R2614	06-11077A40	39
R2620	06-11077A26	10
R2640		not used
R2650	06-11009A39	390 1/4 watt
R2651	06-11077A66	470
R2652	06-11077A66	470
R2653	06-11077A50	100
R2670	06-80147M01	metal plate .05 10% 2 watt
R2671	06-11077A40	39
R2672	06-05621T02	thermistor 50k
R2673	06-11077B11	33k
R2674	06-11077A76	1.2k
R2675	06-11077A26	10

Non-referenced items

26-80158L01	heat sink (for Q2620)
29-80014A03	clip coax terminal (2 used)

Note: For optimum performance, diodes, transistors, and integrated circuits must be ordered by Motorola part numbers.

3/11/92

PL-921017-O

01-80704Y64 Feedthru Bracket and Cable Assembly

REFERENCE NUMBER	MOTOROLA PART NO.	DESCRIPTION
Non-referenced items		
	01-80556B01	6-wire cable assembly (includes P7)
	01-80634B01	feedthru bracket assembly (includes C2601 through C2606, 470 pF feedthru capacitors, 6 used)

HLN8068A PA Hardware Kit, UHF 25 Watt

REFERENCE NUMBER	MOTOROLA PART NO.	DESCRIPTION
Capacitors, chip		
C2641	21-80060M34	43 pF 500V
C2642	21-80060M34	43 pF 500V
C2643	21-80060M33	39 pF 500V
C2644	21-80060M33	39 pF 500V
Connector, receptacle		
J1	09-80131M01	mini UHF coax
J2	09-80255E01	power (includes feedthru)
Connector, plug		
P4	30-80138M07	coaxial cable 158 mm with plug
P5	30-80138M08	coaxial cable 105 mm with plug
Transistors		
Q2630	48-80225C19	NPN; type 2519
Q2640	48-84411L07	NPN; type M1107
Non-referenced items		
	02-00007003	nut 8-32x5/16x1/8 (for J1)
	03-10943M10	screw M3x.5x8 (8 used)
	03-10943M11	screw M3x.5x10 (2 used for J2)
	04-00131974	washer (2 used for J2)
	04-05587G01	washer nylon (for J2)
	04-80943V01	lockwasher (for J1)
	26-80124L01	heat sink
	26-80223M07	PA shield
	32-80014N03	gasket, accessory connector
	42-80281L01	ground clip (2 used for Q2640)
	42-80520B01	ground clip, pc board (2 used)

Note: For optimum performance, diodes, transistors, and integrated circuits must be ordered by Motorola part numbers.

3/11/92

PL-921018-O